

THG 天花管其他系列

Other series of THG ceiling pipes



优选材料



精工制作



钻石品质

THG 天花管其他系列

Other series of THG ceiling pipes

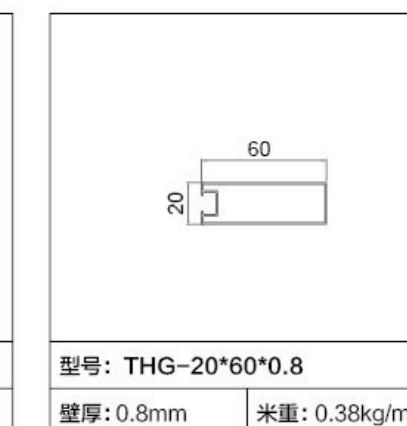
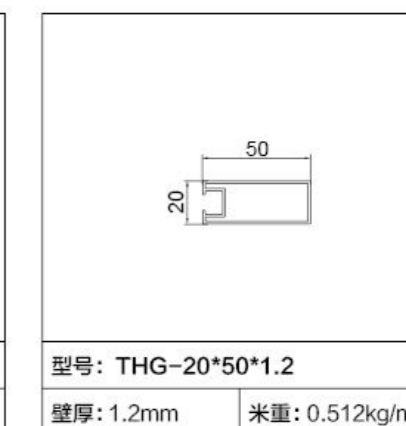
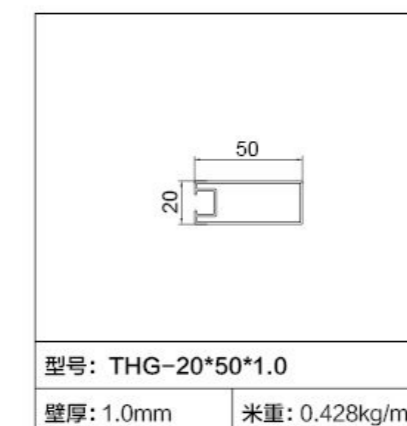
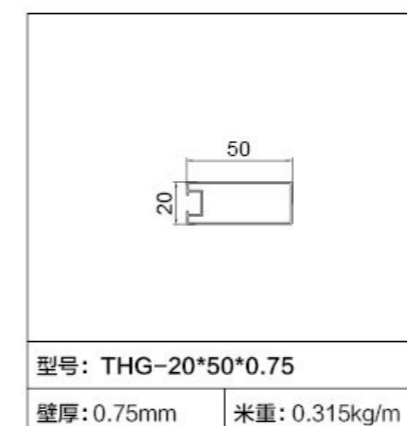
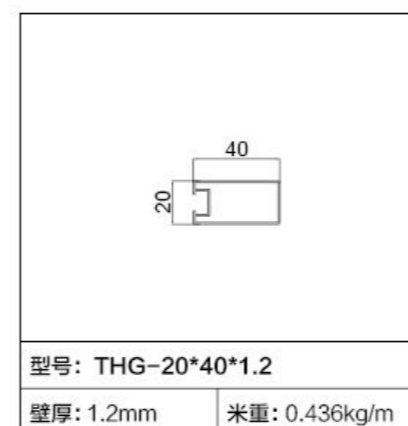
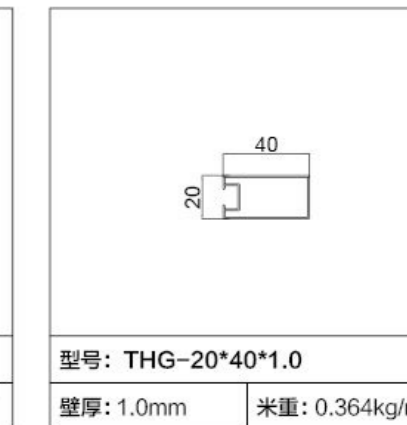
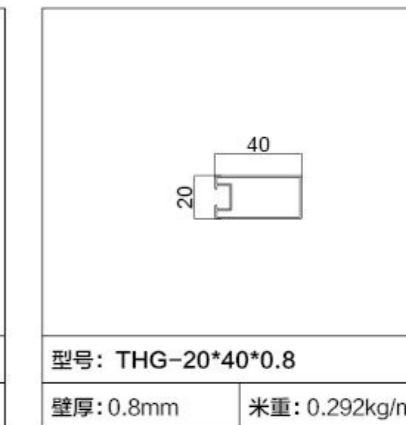
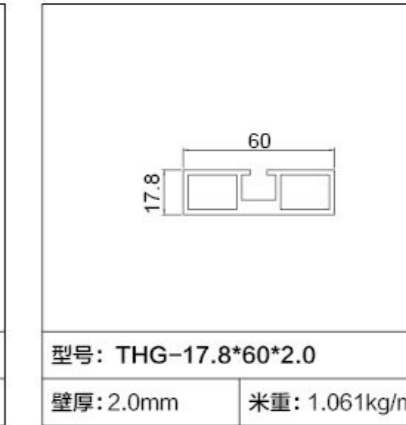
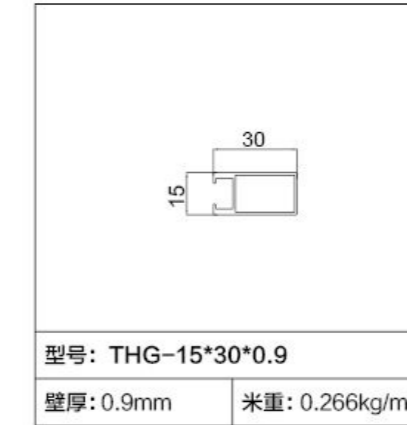
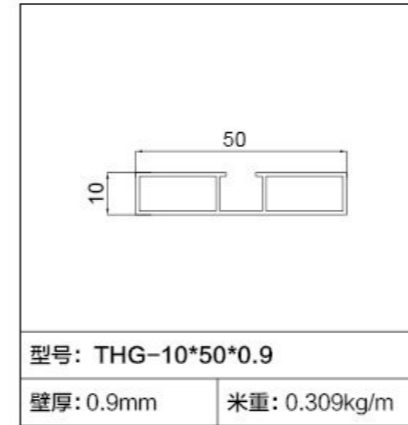
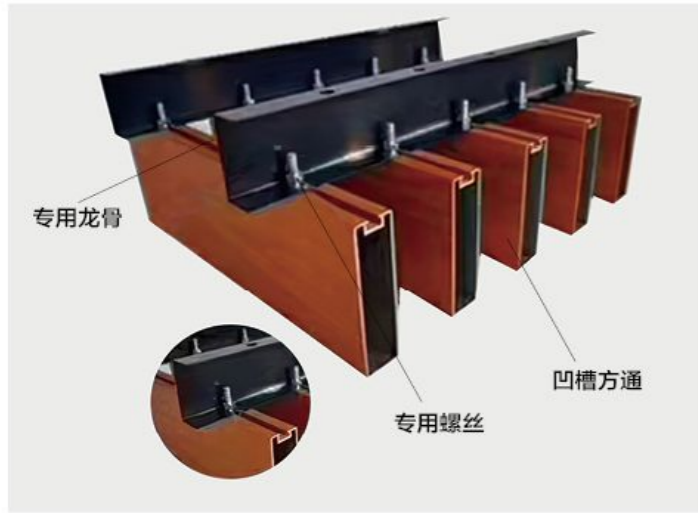



优选材料



精工制作



钻石品质

型号: THG-20*60*0.9 壁厚: 0.9mm 米重: 0.421kg/m	型号: THG-20*60*1.1 壁厚: 1.1mm 米重: 0.523kg/m	型号: THG-20*60*1.2 壁厚: 1.2mm 米重: 0.577kg/m	型号: THG-20*60*1.45 壁厚: 1.45mm 米重: 0.717kg/m	型号: THG-20*80*0.75 壁厚: 0.75mm 米重: 0.438kg/m	型号: THG-20*120*1.2 壁厚: 1.2mm 米重: 0.96kg/m	型号: THG-20*120*1.3 壁厚: 1.3mm 米重: 1.026kg/m	型号: THG-20*120*1.4 壁厚: 1.4mm 米重: 1.1kg/m	型号: THG-20*150*0.85 壁厚: 0.85mm 米重: 0.86kg/m	型号: THG-20*150*1.3 壁厚: 1.3mm 米重: 1.305kg/m
型号: THG-20*80*0.85 壁厚: 0.85mm 米重: 0.495kg/m	型号: THG-20*80*1.0 壁厚: 1.0mm 米重: 0.591kg/m	型号: THG-20*80*1.2 壁厚: 1.2mm 米重: 0.708kg/m	型号: THG-20*100*0.75 壁厚: 0.75mm 米重: 0.518kg/m	型号: THG-20*100*0.85 壁厚: 0.85mm 米重: 0.587kg/m	型号: THG-20*150*1.2 壁厚: 1.2mm 米重: 1.153kg/m	型号: THG-20*150*1.3 壁厚: 1.3mm 米重: 1.246kg/m	型号: THG-20*200*1.5 壁厚: 1.5mm 米重: 1.821kg/m	型号: THG-20*200*1.8 壁厚: 1.8mm 米重: 2.285kg/m	型号: THG-25*25*0.6 壁厚: 0.6mm 米重: 0.187kg/m
型号: THG-20*100*0.95 壁厚: 0.95mm 米重: 0.658kg/m	型号: THG-20*100*1.05 壁厚: 1.05mm 米重: 0.735kg/m	型号: THG-20*100*1.2 壁厚: 1.2mm 米重: 0.839kg/m	型号: THG-20*100*1.4 壁厚: 1.4mm 米重: 0.96kg/m	型号: THG-20*120*1.0 壁厚: 1.0mm 米重: 0.799kg/m	型号: THG-25*50*0.75 壁厚: 0.75mm 米重: 0.335kg/m	型号: THG-25*50*1.0 壁厚: 1.0mm 米重: 0.455kg/m	型号: THG-25*50*1.2 壁厚: 1.2m 米重: 0.545kg/m	型号: THG-25X50-1.35 壁厚: 1.35mm 米重: 0.6kg/m	型号: THG-25*60*0.8 壁厚: 0.8mm 米重: 0.401kg/m



优选材料



精工制作



钻石品质

型号: THG-25*70*0.8 壁厚: 0.8mm 米重: 0.444kg/m	型号: THG-25*70*1.0 壁厚: 1.0mm 米重: 0.564kg/m	型号: THG-25*70*1.2 壁厚: 1.2mm 米重: 0.675kg/m	型号: THG-25*75*0.8 壁厚: 0.8mm 米重: 0.466kg/m	型号: THG-25*80*0.8 壁厚: 0.8mm 米重: 0.488kg/m	型号: THG-25*120*1.2 壁厚: 1.2 米重: 1.0kg/m	型号: THG-25*125*1.1 壁厚: 1.1mm 米重: 0.94kg/m	型号: THG-25*150*1.45 壁厚: 1.45mm 米重: 1.424kg/m	型号: THG-25*200*1.5 壁厚: 1.5mm 米重: 1.887kg/m	型号: THG-25*200*1.8 壁厚: 1.8mm 米重: 2.28kg/m
型号: THG-25*80*1.0 壁厚: 1.0mm 米重: 0.608kg/m	型号: THG-25*80*1.2 壁厚: 1.2 米重: 0.741kg/m	型号: THG-25*85*0.9 壁厚: 0.9mm 米重: 0.574kg/m	型号: THG-25*100*0.75 壁厚: 0.75mm 米重: 0.537kg/m	型号: THG-25*100*0.8 壁厚: 0.8mm 米重: 0.575kg/m	型号: THG-30*20*0.95 壁厚: 0.95mm 米重: 0.312kg/m	型号: THG-30*30*0.8 壁厚: 0.8mm 米重: 0.209kg/m	型号: THG-30*30*1.0 壁厚: 1.0mm 米重: 0.364kg/m	型号: THG-30*30*1.2 壁厚: 1.2mm 米重: 0.436kg/m	型号: THG-30*40*0.6 壁厚: 0.6mm 米重: 0.253kg/m
型号: THG-25*100*0.85 壁厚: 0.85mm 米重: 0.61kg/m	型号: THG-25*100*0.9 壁厚: 0.9mm 米重: 0.641kg/m	型号: THG-25*100*0.95 壁厚: 0.95mm 米重: 0.698kg/m	型号: THG-25*100*1.15 壁厚: 1.15mm 米重: 0.824kg/m	型号: THG-25*120*1.0 壁厚: 1.0mm 米重: 0.826kg/m	型号: THG-30*40*0.6 壁厚: 0.6mm 米重: 0.253kg/m	型号: THG-30*40*0.65 壁厚: 0.65mm 米重: 0.273kg/m	型号: THG-30*40*0.85 壁厚: 0.85mm 米重: 0.357kg/m	型号: THG-30*40*1.0 壁厚: 1.0mm 米重: 0.419kg/m	型号: THG-30*40*1.2 壁厚: 1.2mm 米重: 0.502kg/m



优选材料



精工制作



钻石品质

型号: THG-30*50*0.62 壁厚: 0.62mm 米重: 0.294kg/m	型号: THG-30*50*0.7 壁厚: 0.7mm 米重: 0.334kg/m	型号: THG-30*50*0.9 壁厚: 0.9mm 米重: 0.433kg/m	型号: THG-30*50*1.2 壁厚: 1.2mm 米重: 0.566kg/m	型号: THG-30*50*1.4 壁厚: 1.4mm 米重: 0.66kg/m	型号: THG-30*70*1.0 壁厚: 1.0mm 米重: 0.581kg/m	型号: THG-30*70*1.2 壁厚: 1.2mm 米重: 0.698kg/m	型号: THG-30*70*1.4 壁厚: 1.4mm 米重: 0.818kg/m	型号: THG-30*80*0.7 壁厚: 0.7mm 米重: 0.448kg/m	型号: THG-30*80*1.0 壁厚: 1.0mm 米重: 0.645kg/m
型号: THG-30*50*0.8 壁厚: 0.8mm 米重: 0.38kg/m	型号: THG-30*50*0.9 壁厚: 0.9mm 米重: 0.426kg/m	型号: THG-30*50*1.13 壁厚: 1.13mm 米重: 0.535kg/m	型号: THG-30*50*1.3 壁厚: 1.3mm 米重: 0.607kg/m	型号: THG-30*60*0.55 壁厚: 0.55mm 米重: 0.291kg/m	型号: THG-30*80*1.2 壁厚: 1.2mm 米重: 0.773kg/m	型号: THG-30*80*1.4 壁厚: 1.4mm 米重: 0.89kg/m	型号: THG-30*80*0.9 壁厚: 0.9mm 米重: 0.573kg/m	型号: THG-30*80*1.9 壁厚: 1.9mm 米重: 1.197kg/m	型号: THG-30*80*2.0 壁厚: 2.0mm 米重: 1.39kg/m
型号: THG-30*60*0.8 壁厚: 0.8mm 米重: 0.422kg/m	型号: THG-30*60*1.0 壁厚: 1.0mm 米重: 0.537kg/m	型号: THG-30*60*1.2 壁厚: 1.2mm 米重: 0.643kg/m	型号: THG-30*60*1.4 壁厚: 1.4mm 米重: 0.737kg/m	型号: THG-30*70*0.8 壁厚: 0.8mm 米重: 0.466kg/m	型号: THG-30*90*0.8 壁厚: 0.8mm 米重: 0.553kg/m	型号: THG-30*90*1.05 壁厚: 1.05mm 米重: 0.727kg/m	型号: THG-30*90*1.2 壁厚: 1.2mm 米重: 0.829kg/m	型号: THG-30*100*0.7 壁厚: 0.7mm 米重: 0.517kg/m	型号: THG-30*100*0.7 壁厚: 0.7mm 米重: 0.522kg/m









优选材料

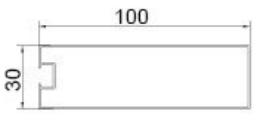
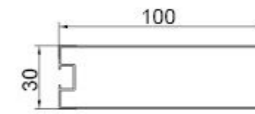
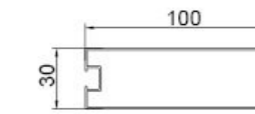
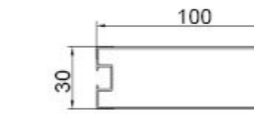
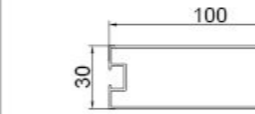
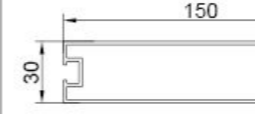
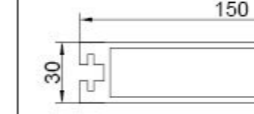
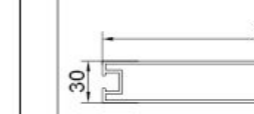
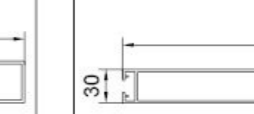
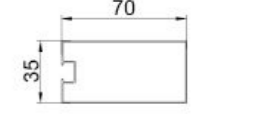
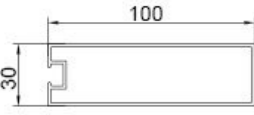
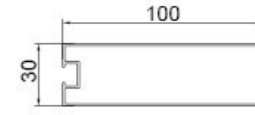
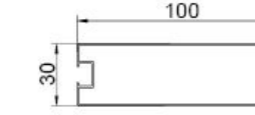
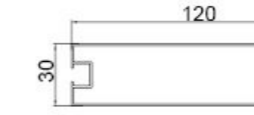
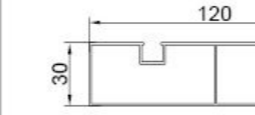
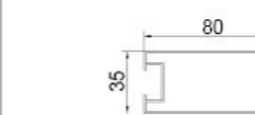
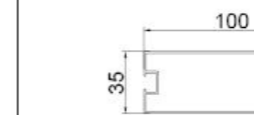

精工制作

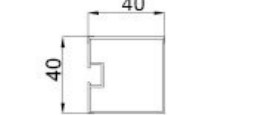
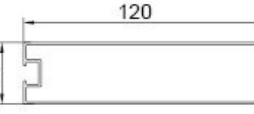
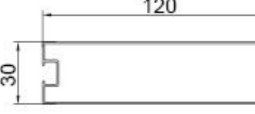
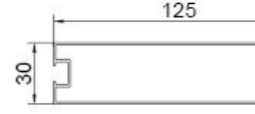
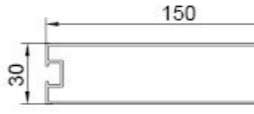
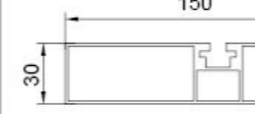
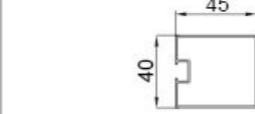

钻石品质

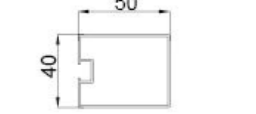
									
型号: THG-30*100*0.75 壁厚: 0.75mm 米重: 0.561kg/m	型号: THG-30*100*0.8 壁厚: 0.8mm 米重: 0.596kg/m	型号: THG-30*100*0.85 壁厚: 0.85mm 米重: 0.633kg/m	型号: THG-30*100*0.9 壁厚: 0.9mm 米重: 0.671kg/m	型号: THG-30*100*1.1 壁厚: 1.1mm 米重: 0.818kg/m	型号: THG-30*150*1.6 壁厚: 1.6mm 米重: 1.627kg/m	型号: THG-30*150*3.0 壁厚: 3.0mm 米重: 3.292kg/m	型号: THG-30*200*1.8 壁厚: 1.8mm 米重: 2.329kg/m	型号: THG-30*200*1.5 壁厚: 1.5mm 米重: 1.927kg/m	型号: THG-35*70*0.7 壁厚: 0.7mm 米重: 0.427kg/m
									
型号: THG-30*100*1.4 壁厚: 1.4mm 米重: 1.039kg/m	型号: THG-30*100*1.7 壁厚: 1.7mm 米重: 1.241kg/m	型号: THG-30*100*2.0 壁厚: 2.0mm 米重: 1.427kg/m	型号: THG-30*120*1.0 壁厚: 1.0mm 米重: 0.865kg/m	型号: THG-30*120*1.05 壁厚: 1.05mm 米重: 1.016kg/m	型号: THG-35*80*1.0 壁厚: 1.0mm 米重: 0.688kg/m	型号: THG-35*100*1.0 壁厚: 1.0mm 米重: 0.772kg/m	型号: THG-40*40*0.75 壁厚: 0.75mm 米重: 0.355kg/m	型号: THG-40*40*1.0 壁厚: 1.0mm 米重: 0.474kg/m	型号: THG-40*40*1.2 壁厚: 1.2mm 米重: 0.567kg/m
									
型号: THG-30*120*1.2 壁厚: 1.2mm 米重: 1.022kg/m	型号: THG-30*120*1.4 壁厚: 1.4mm 米重: 1.192kg/m	型号: THG-30*125*1.1 壁厚: 1.1mm 米重: 0.968kg/m	型号: THG-30*150*1.2 壁厚: 1.2mm 米重: 1.218kg/m	型号: THG-30*150*1.5 壁厚: 1.5mm 米重: 1.96kg/m	型号: THG-40*45*1.5 壁厚: 1.5mm 米重: 1.507kg/m	型号: THG-40*50*0.8 壁厚: 0.8mm 米重: 0.57kg/m	型号: THG-40*50*0.85 壁厚: 0.85mm 米重: 0.426kg/m	型号: THG-40*50*1.0 壁厚: 1.0mm 米重: 0.528kg/m	型号: THG-40*50*1.2 壁厚: 1.2mm 米重: 0.633kg/m



型号: THG-40*60*0.7 壁厚: 0.7mm 米重: 0.409kg/m	型号: THG-40*60*0.8 壁厚: 0.8mm 米重: 0.466kg/m	型号: THG-40*60*0.8 壁厚: 0.8mm 米重: 0.466kg/m	型号: THG-40*60*1.0 壁厚: 1.0mm 米重: 0.581kg/m	型号: THG-40*60*1.2 壁厚: 1.2mm 米重: 0.708kg/m	型号: THG-40*80*0.8 壁厚: 0.8mm 米重: 0.553kg/m	型号: THG-40*80*1.0 壁厚: 1.0mm 米重: 0.799kg/m	型号: THG-40*80*1.1 壁厚: 1.1mm 米重: 0.769kg/m	型号: THG-40*80*1.2 壁厚: 1.2mm 米重: 0.839kg/m	型号: THG-40*80*1.65 壁厚: 1.65mm 米重: 1.126kg/m
型号: THG-40*70*0.7 壁厚: 0.7mm 米重: 0.448kg/m	型号: THG-40*70*0.8 壁厚: 0.8mm 米重: 0.509kg/m	型号: THG-40*70*1.0 壁厚: 1.0mm 米重: 0.636kg/m	型号: THG-40*75*1.0 壁厚: 1.0mm 米重: 0.745kg/m	型号: THG-40*70*1.2 壁厚: 1.2mm 米重: 0.764kg/m	型号: THG-40*80*1.95 壁厚: 1.95mm 米重: 1.336kg/m	型号: THG-40*90*0.75 壁厚: 0.75mm 米重: 0.561kg/m	型号: THG-40*90*1.95 壁厚: 1.95mm 米重: 1.471kg/m	型号: THG-40*100*0.7 壁厚: 0.7mm 米重: 0.555kg/m	型号: THG-40*100*0.75 壁厚: 0.75mm 米重: 0.602kg/m
型号: THG-40*70*1.4 壁厚: 1.4mm 米重: 0.889kg/m	型号: THG-40*70*1.8 壁厚: 1.8mm 米重: 1.14kg/m	型号: THG-40*80*0.65 壁厚: 0.65mm 米重: 0.454kg/m	型号: THG-40*80*0.7 壁厚: 0.7mm 米重: 0.484kg/m	型号: THG-40*80*0.75 壁厚: 0.75mm 米重: 0.514kg/m	型号: THG-40*100*0.9 壁厚: 0.9mm 米重: 0.722kg/m	型号: THG-40*100*1.0 壁厚: 1.0mm 米重: 0.799kg/m	型号: THG-40*100*1.1 壁厚: 1.1mm 米重: 0.889kg/m	型号: THG-40*100*1.2 壁厚: 1.2mm 米重: 0.96kg/m	型号: THG-40*100*1.35 壁厚: 1.35mm 米重: 1.072kg/m



型号: THG-40*120*0.95 壁厚: 0.95mm 米重: 0.865kg/m	型号: THG-40*120*1.1 壁厚: 1.1mm 米重: 0.998kg/m	型号: THG-40*120*1.2 壁厚: 1.2mm 米重: 1.08kg/m	型号: THG-40*120*1.4 壁厚: 1.4mm 米重: 1.264kg/m	型号: THG-40*150*1.2 壁厚: 1.2mm 米重: 1.284kg/m	型号: THG-50*50*1.2 壁厚: 1.2mm 米重: 0.698kg/m	型号: THG-50*50*1.4 壁厚: 1.4mm 米重: 0.813kg/m	型号: THG-50*50*1.5 壁厚: 1.5mm 米重: 1.507kg/m	型号: THG-50*50*2.0 壁厚: 2.0mm 米重: 1.134kg/m	型号: THG-50*60*0.8 壁厚: 0.8mm 米重: 0.509kg/m
型号: THG-40*150*1.7 壁厚: 1.7mm 米重: 1.845kg/m	型号: THG-40*200*1.5 壁厚: 1.5mm 米重: 2.009kg/m	型号: THG-40*200*1.8 壁厚: 1.8mm 米重: 2.427kg/m	型号: THG-45*100*1.6 壁厚: 1.6mm 米重: 1.31kg/m	型号: THG-49.8*69.8*1.2 壁厚: 1.2mm 米重: 0.815kg/m	型号: THG-50*60*1.0 壁厚: 1.0mm 米重: 0.636kg/m	型号: THG-50*60*1.2 壁厚: 1.2mm 米重: 0.764kg/m	型号: THG-50*70*0.75 壁厚: 0.75mm 米重: 0.52kg/m	型号: THG-50*70*0.8 壁厚: 0.8mm 米重: 0.553kg/m	型号: THG-50*70*1.0 壁厚: 1.0mm 米重: 0.69kg/m
型号: THG-50*50 壁厚: 0.62mm 米重: 0.376kg/m	型号: THG-50*50*0.7 壁厚: 0.7mm 米重: 0.408kg/m	型号: THG-50*50*0.8 壁厚: 0.8mm 米重: 0.464kg/m	型号: THG-50*50*0.9 壁厚: 0.9mm 米重: 0.526kg/m	型号: THG-50*50*1.1 壁厚: 1.1mm 米重: 0.635kg/m	型号: THG-50*70*1.2 壁厚: 1.2mm 米重: 0.829kg/m	型号: THG-50*70*1.75 壁厚: 1.75mm 米重: 1.2kg/m	型号: THG-50*70*1.43 壁厚: 1.43mm 米重: 1.001kg/m	型号: THG-50*80*0.7 壁厚: 0.7mm 米重: 0.524kg/m	型号: THG-50*80*0.8 壁厚: 0.8mm 米重: 0.596kg/m



型号: THG-50*80*0.8 壁厚: 0.8mm 米重: 0.599kg/m	型号: THG-50*80*0.85 壁厚: 0.85mm 米重: 0.634kg/m	型号: THG-50*80*0.9 壁厚: 0.9mm 米重: 0.67kg/m	型号: THG-50*80*1.1 壁厚: 1.1mm 米重: 0.818kg/m	型号: THG-50*80*1.2 壁厚: 1.2mm 米重: 0.904kg/m	型号: THG-50*100*0.9 壁厚: 0.9mm 米重: 0.771kg/m	型号: THG-50*100*0.9 壁厚: 0.9mm 米重: 0.771kg/m	型号: THG-50*100*1.0 壁厚: 1.0mm 米重: 0.854kg/m	型号: THG-50*100*1.022 壁厚: 1.022mm 米重: 1.2kg/m	型号: THG-50*100*1.08 壁厚: 1.08mm 米重: 0.917kg/m
型号: THG-50*80*1.5 壁厚: 1.5mm 米重: 1.122kg/m	型号: THG-50*90*0.85 壁厚: 0.85mm 米重: 0.68kg/m	型号: THG-50*90*1.0 壁厚: 1.0mm 米重: 0.801kg/m	型号: THG-50*90*1.2 壁厚: 1.2mm 米重: 0.96kg/m	型号: THG-50*90*1.4 壁厚: 1.4mm 米重: 1.119kg/m	型号: THG-50*100*1.15 壁厚: 1.15mm 米重: 0.98kg/m	型号: THG-50*100*1.35 壁厚: 1.35mm 米重: 1.153kg/m	型号: THG-50*100*1.35 壁厚: 1.35mm 米重: 1.149kg/m	型号: THG-50*100*1.45 壁厚: 1.45mm 米重: 1.238kg/m	型号: THG-50*100*1.75 壁厚: 1.75mm 米重: 1.491kg/m
型号: THG-50*95*0.82 壁厚: 0.82mm 米重: 0.68kg/m	型号: THG-50*95*1.08 壁厚: 1.08mm 米重: 0.895kg/m	型号: THG-50*100*0.75 壁厚: 0.75mm 米重: 0.641kg/m	型号: THG-50*100*0.8 壁厚: 0.8mm 米重: 0.686kg/m	型号: THG-50*100*0.85 壁厚: 0.85mm 米重: 0.726kg/m	型号: THG-50*100*2.4 壁厚: 2.4mm 米重: 2.024kg	型号: THG-50*120*0.95 壁厚: 0.95mm 米重: 0.921kg/m	型号: THG-50*120*1.05 壁厚: 1.017mm 米重: 1.05kg/m	型号: THG-50*120*1.1 壁厚: 1.1mm 米重: 1.059kg/m	型号: THG-50*120*1.2 壁厚: 1.2mm 米重: 1.152kg/m



优选材料



精工制作



钻石品质

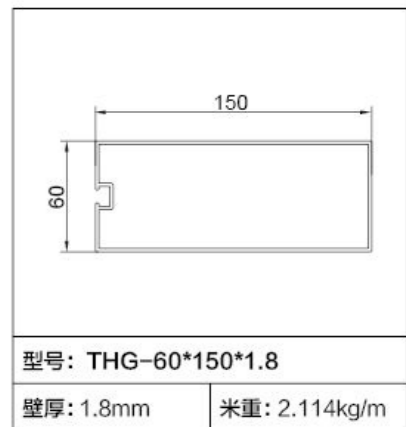
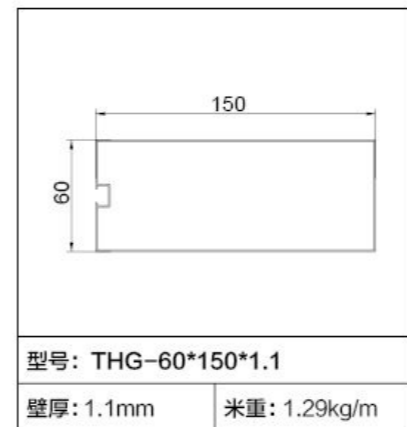
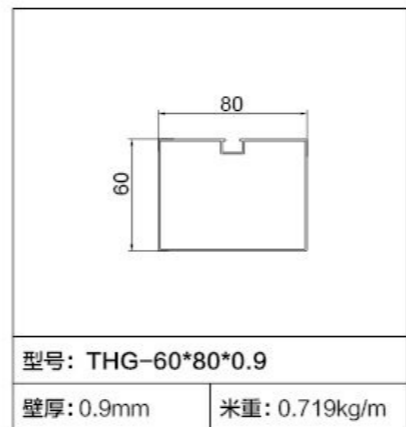
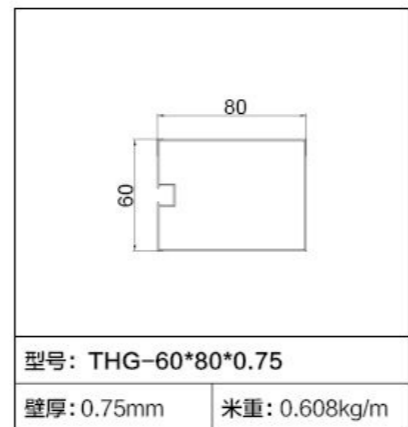
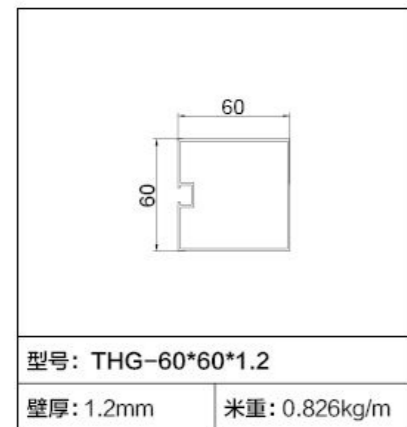
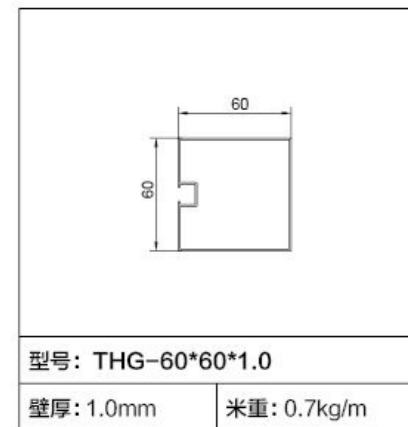
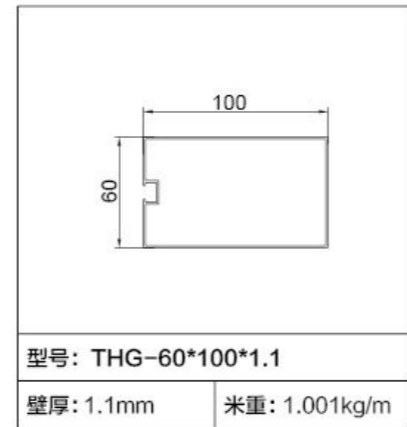
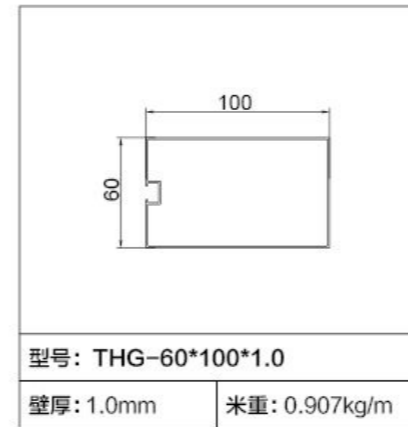
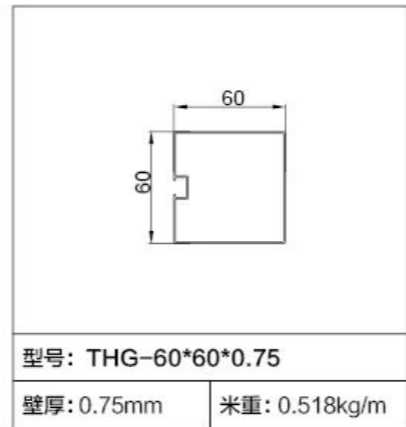
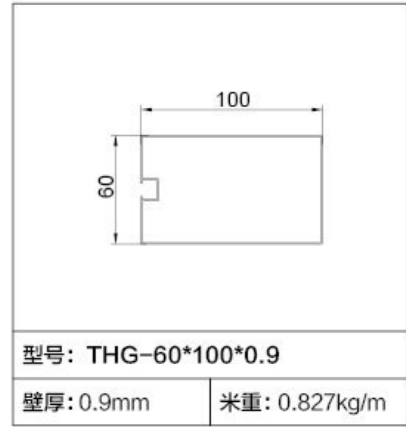
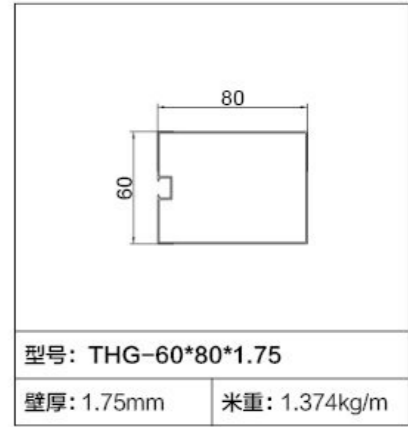
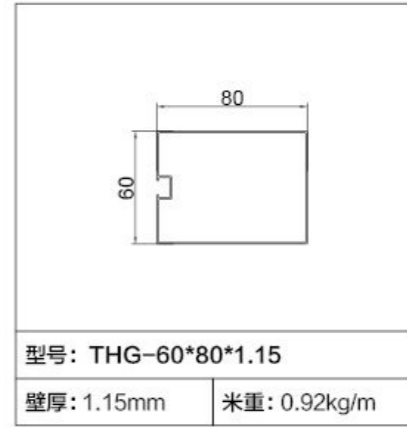
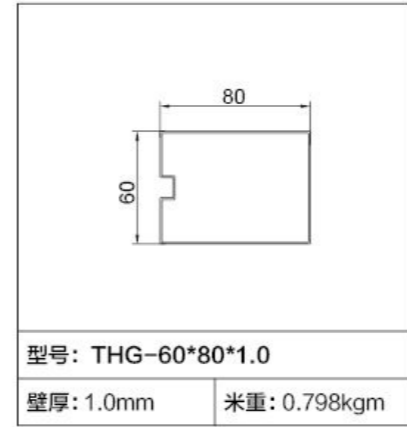
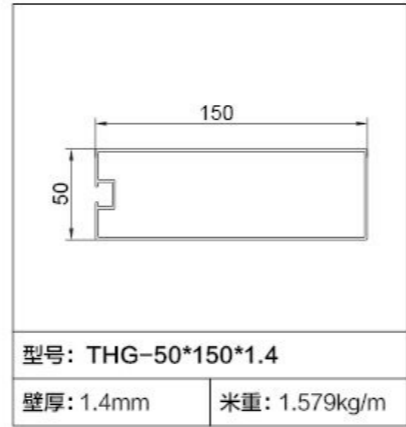
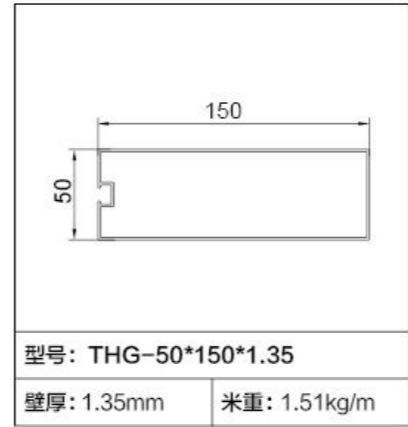
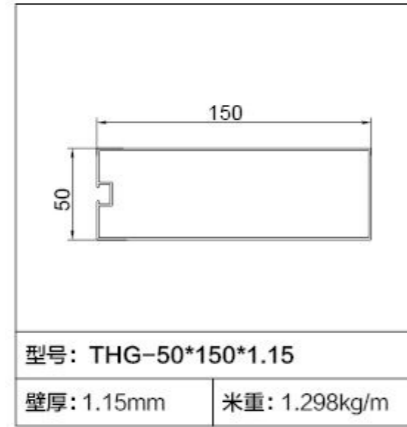
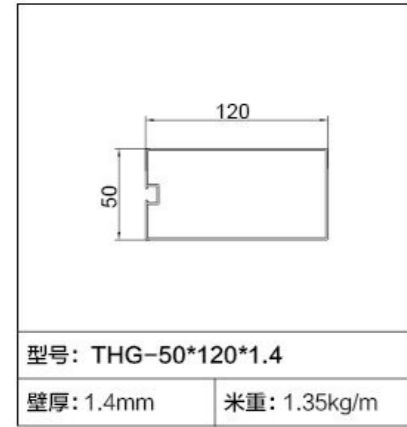

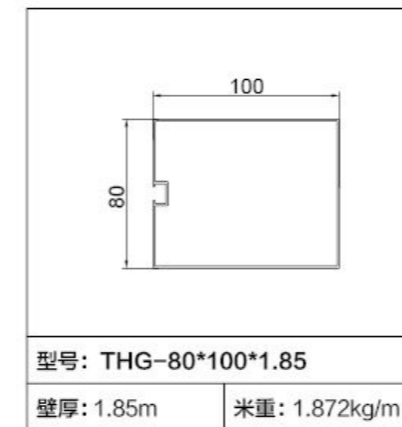
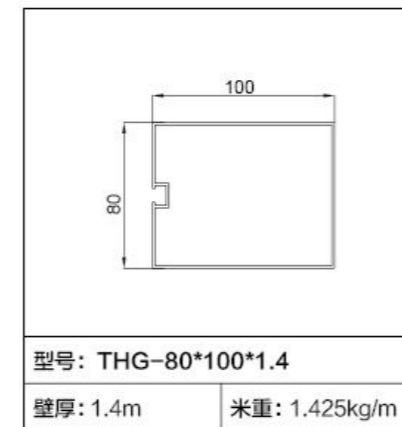
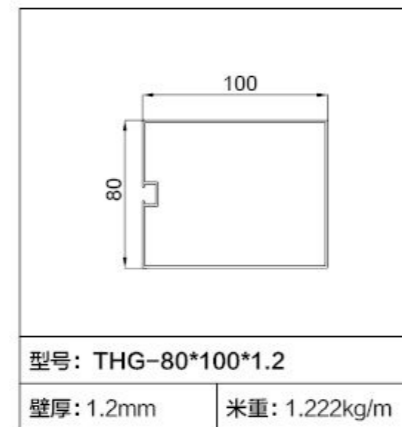
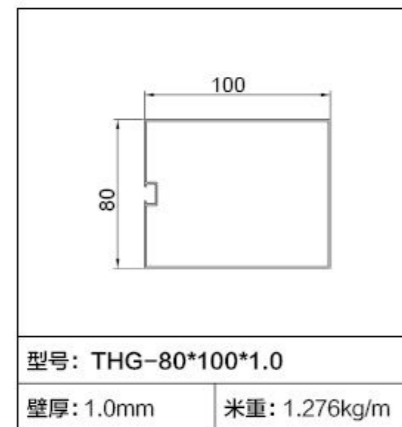
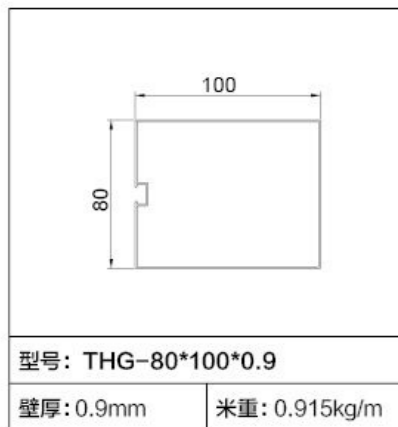
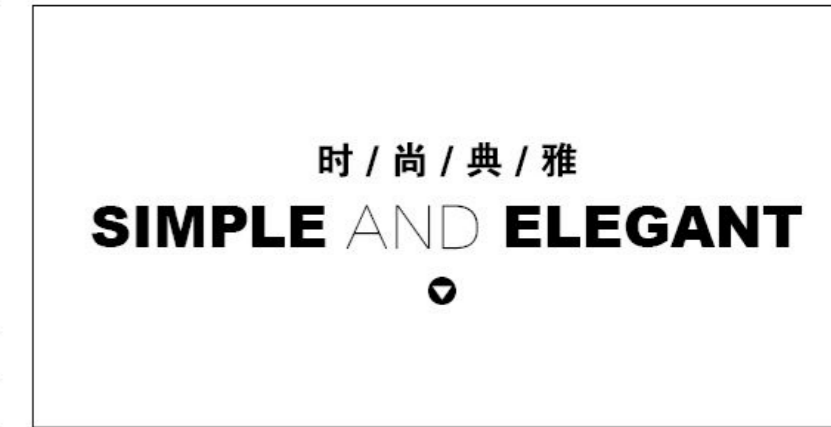
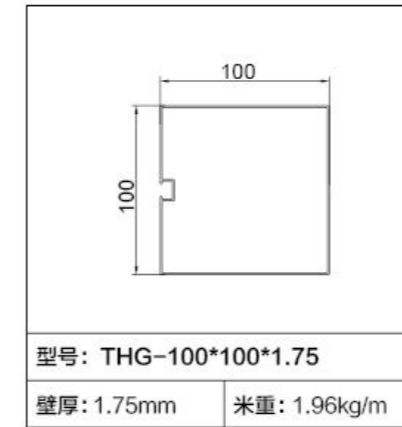
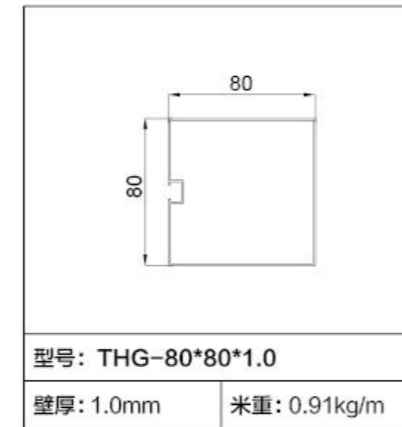
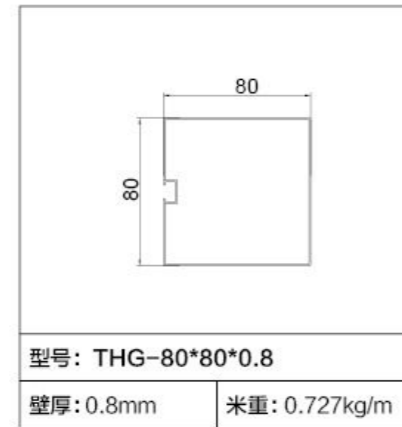
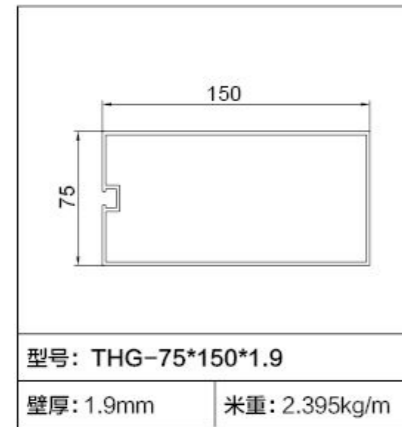
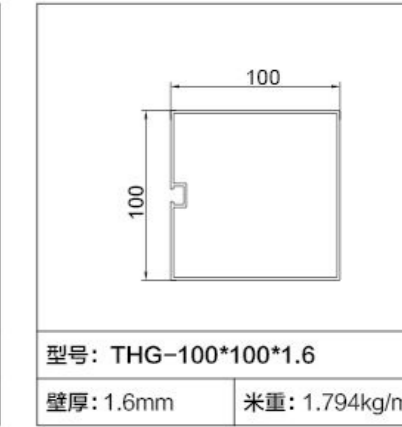
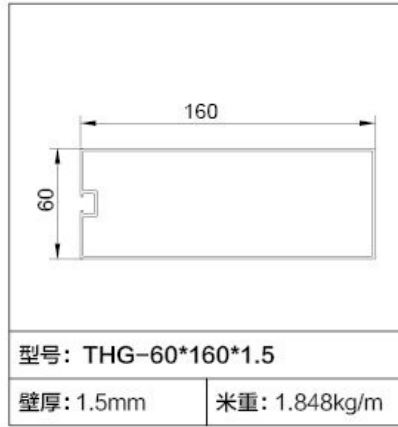

圆管系列 Round pipe series

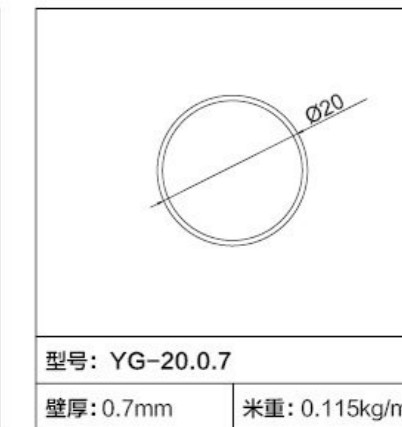
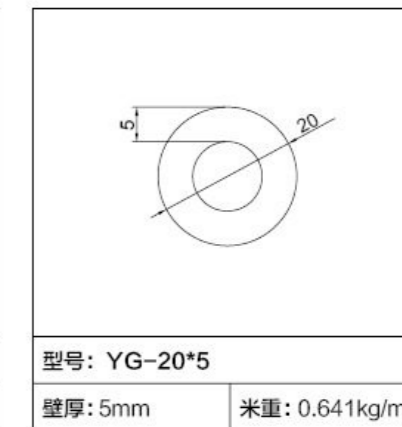
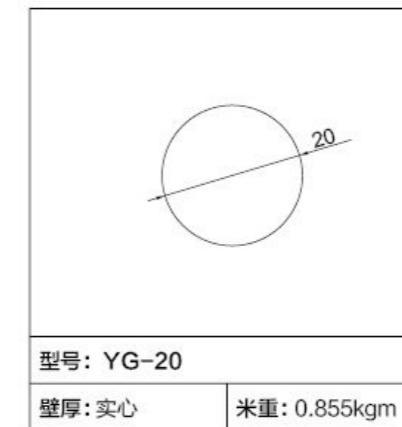

圆管系列

Round pipe series



优选材料



精工制作



钻石品质

圆管系列

Round pipe series

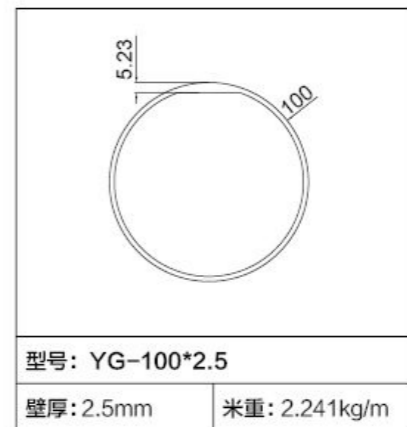
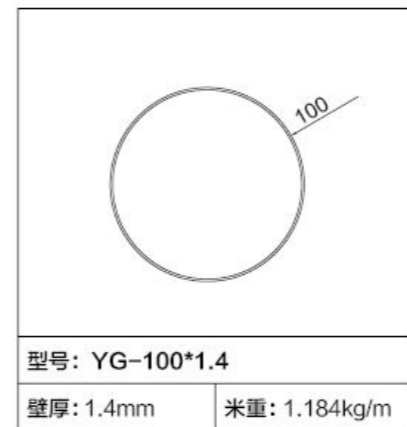
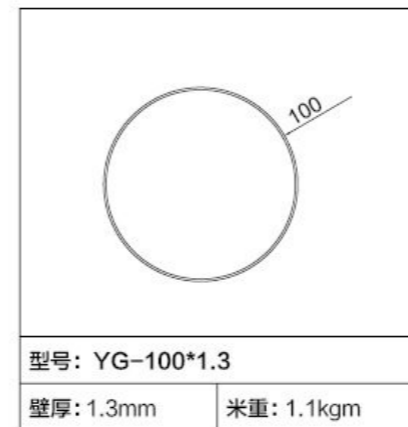
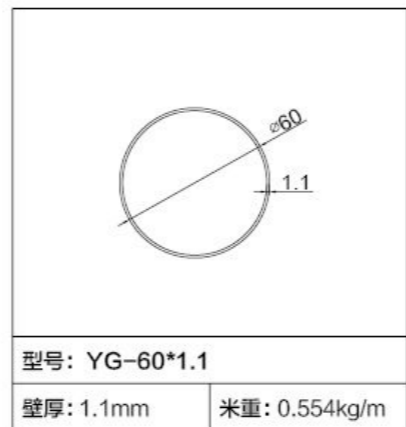
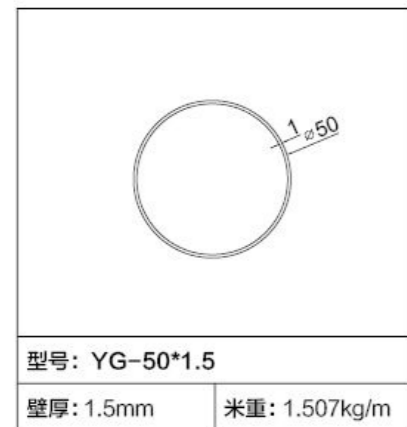
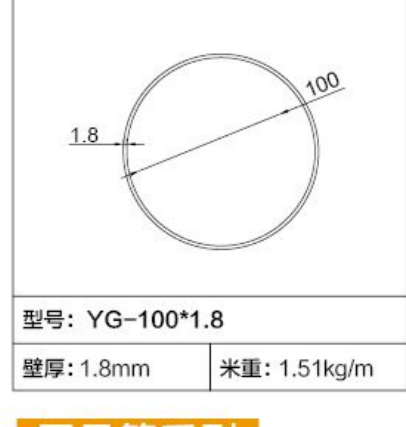
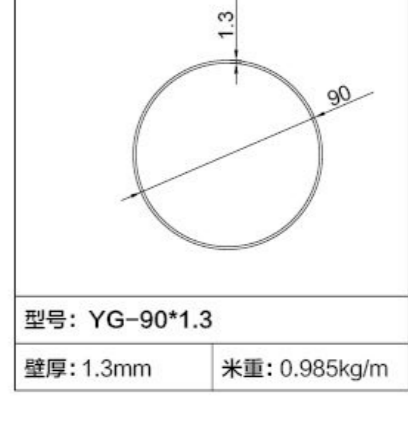
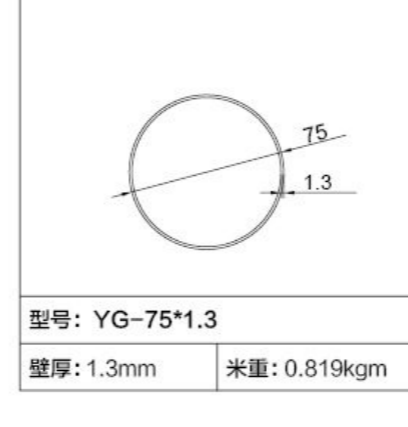
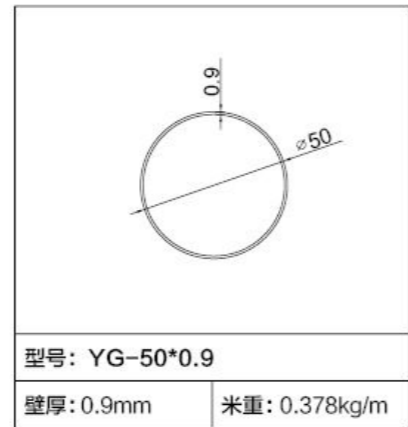
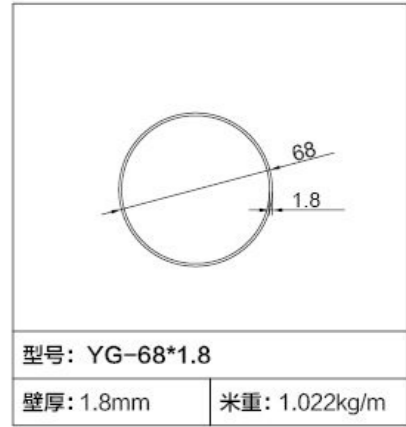
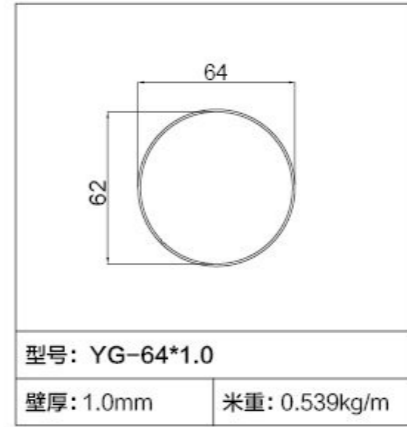
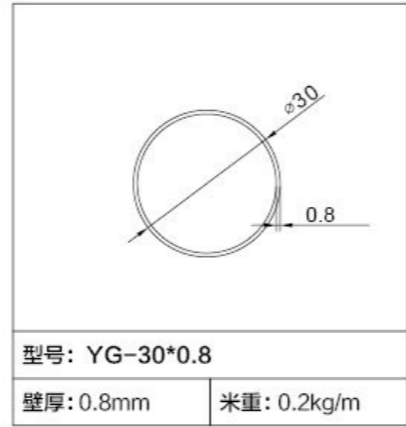
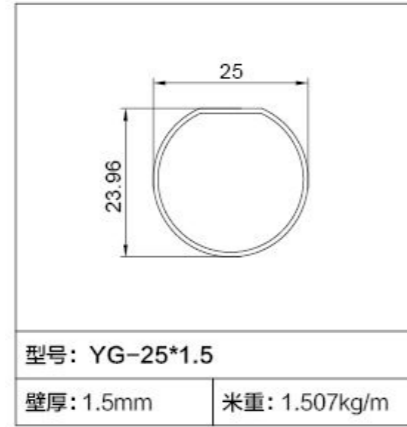
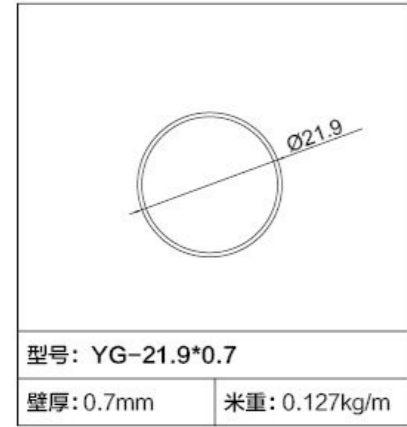
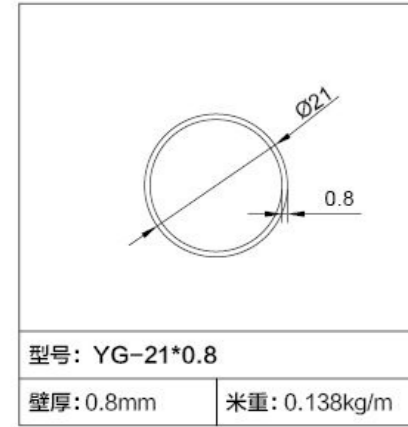

圆吊管系列

Round hanging pipe series

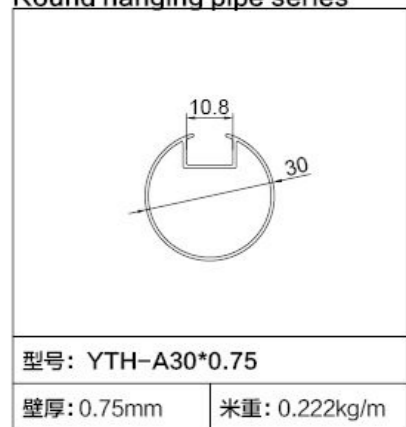

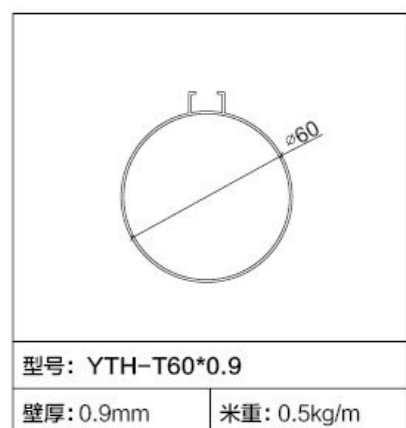
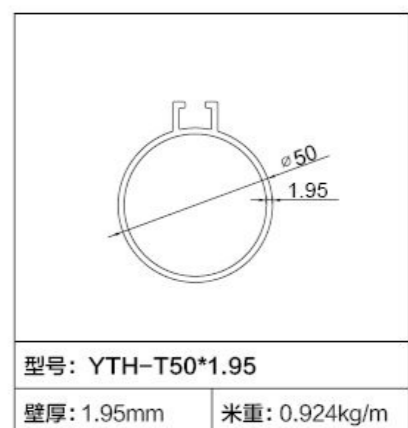
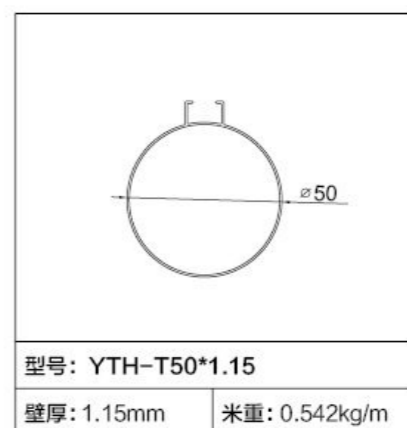
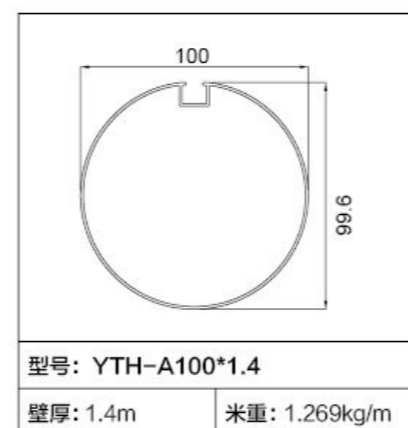
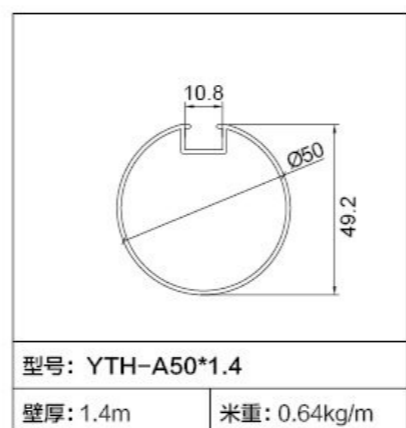
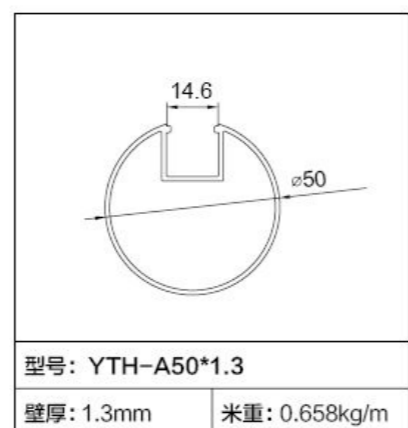
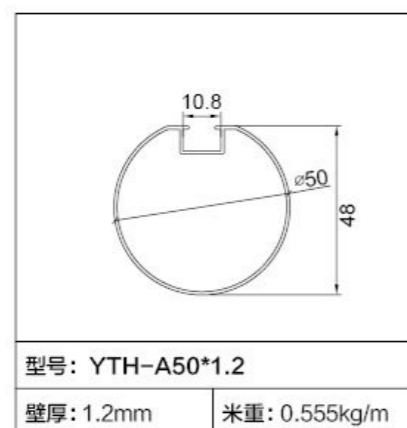
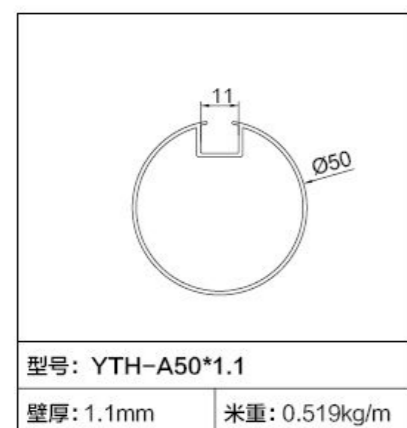
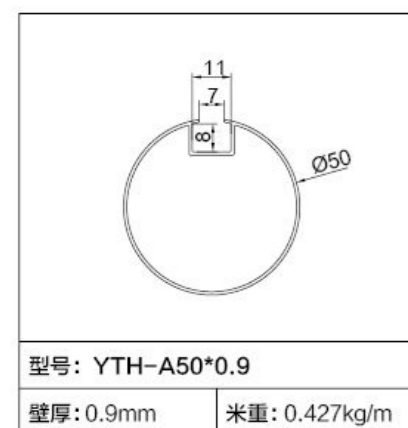
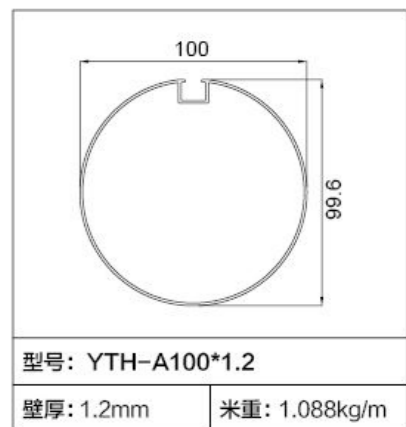
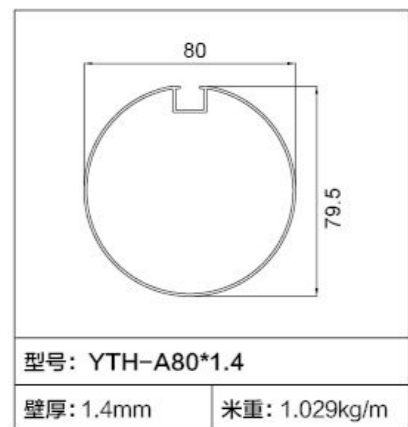
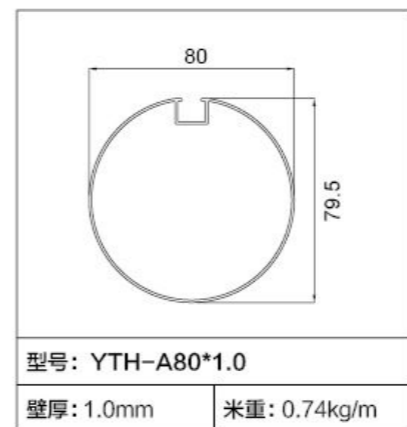
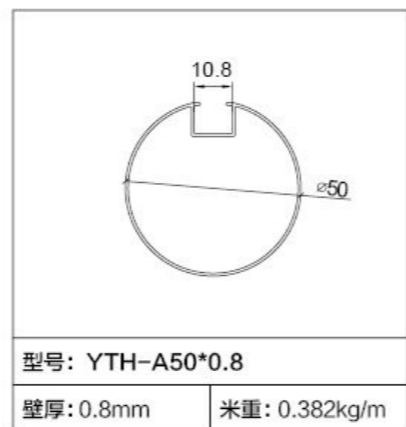
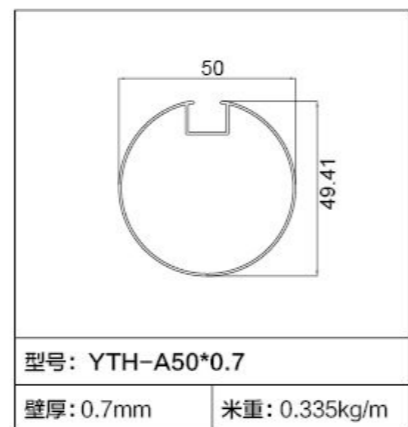
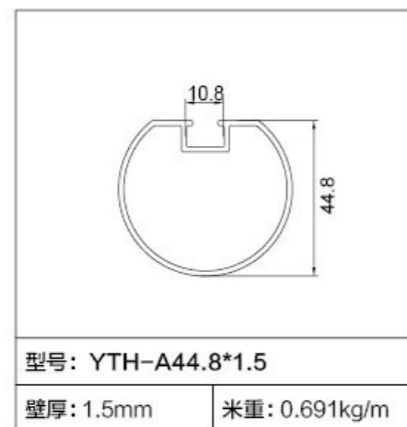
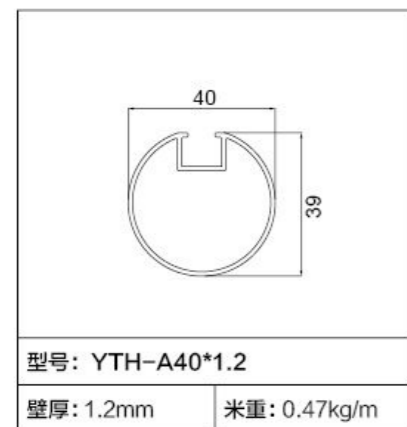
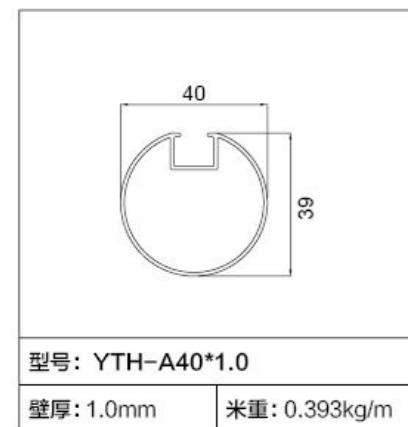
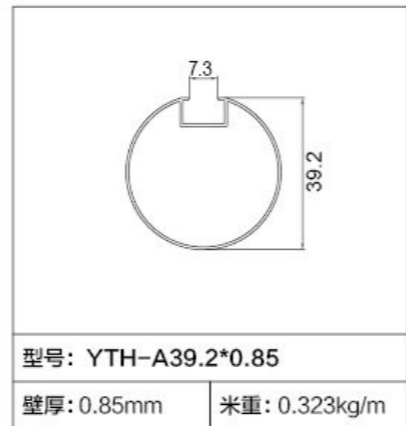
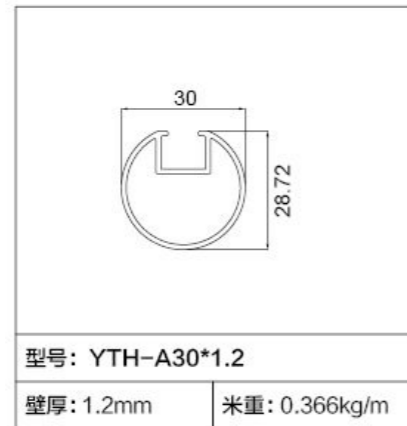
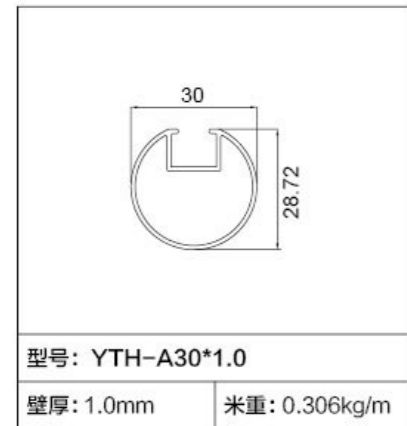

圆吊管系列

Round hanging pipe series

 优选材料
 精工制作
 钻石品质

子弹头系列

Bullet head series

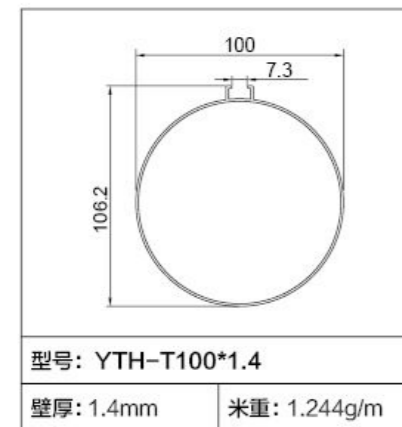
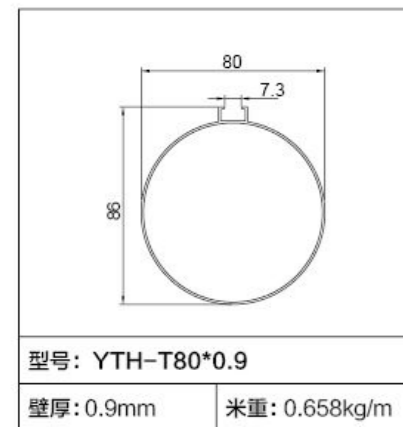

子弹头系列

Bullet head series

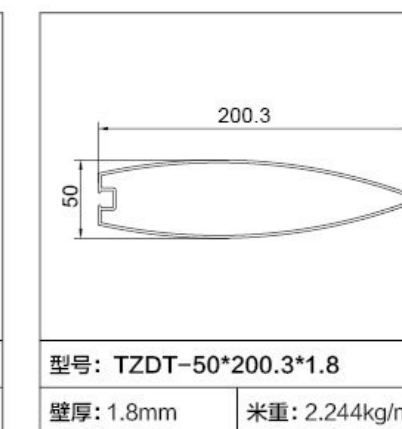
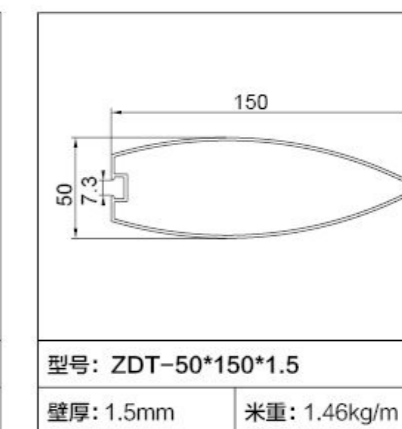
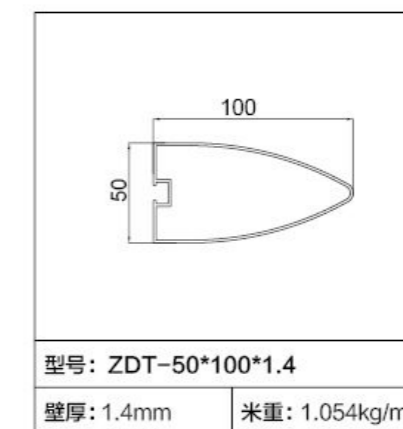
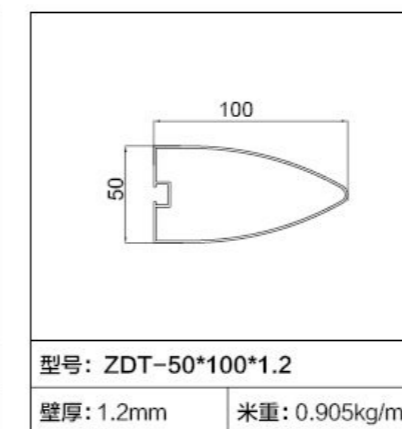
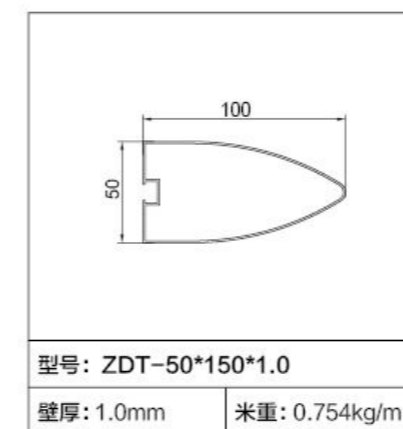
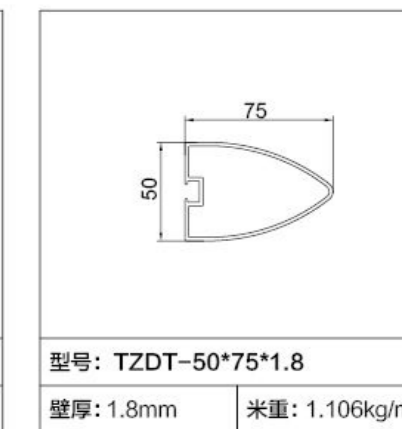
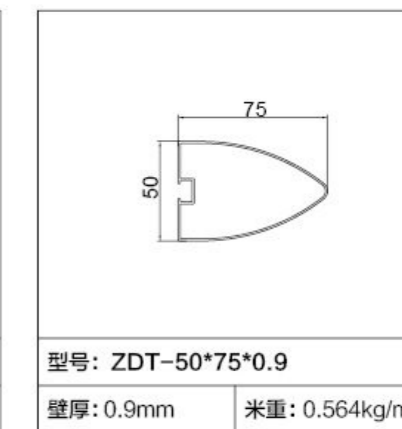
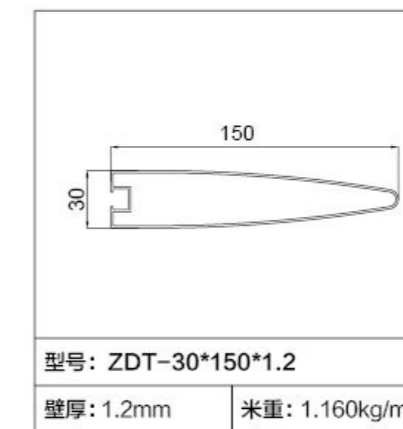
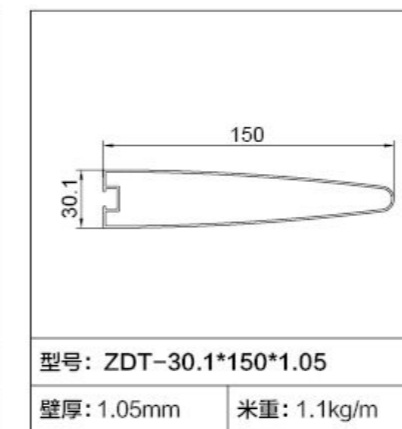
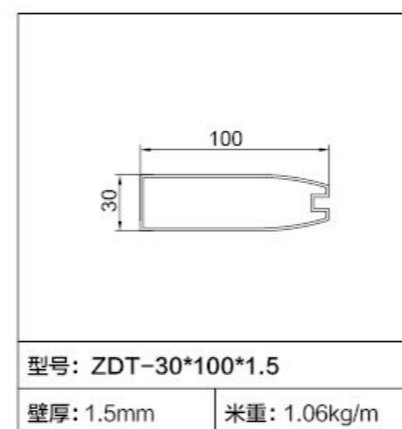
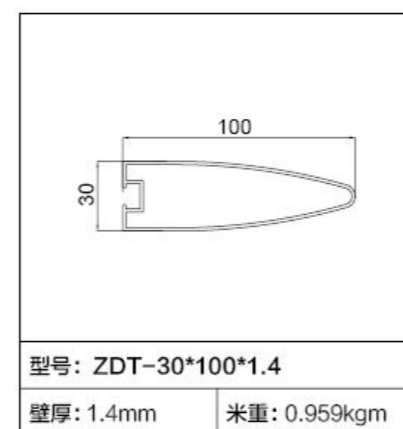
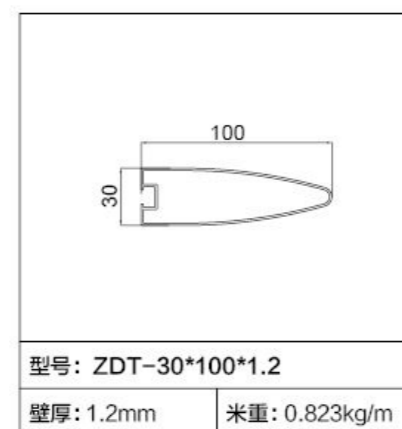
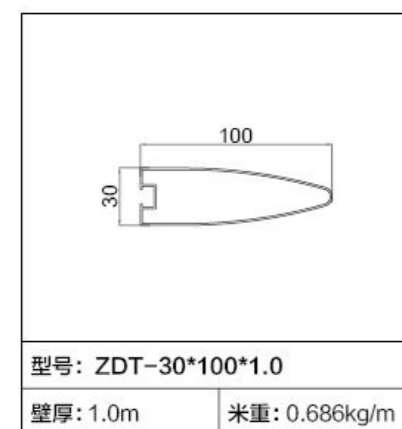
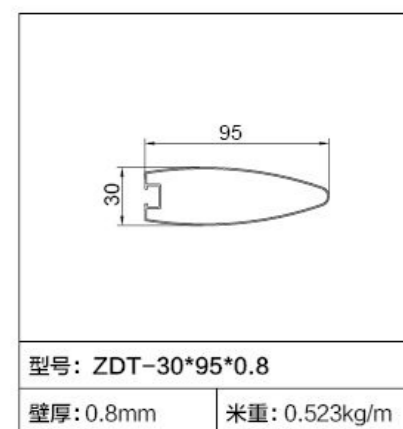
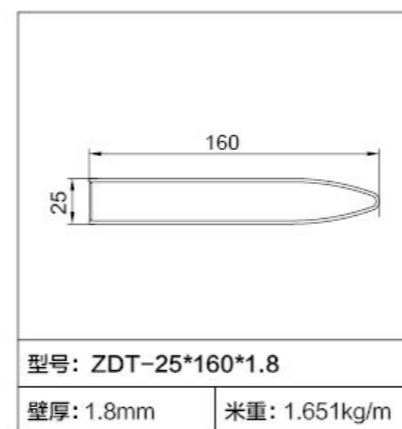
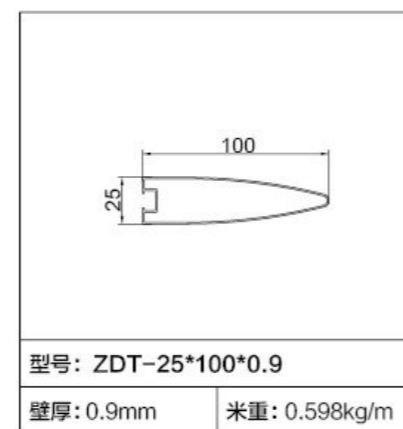
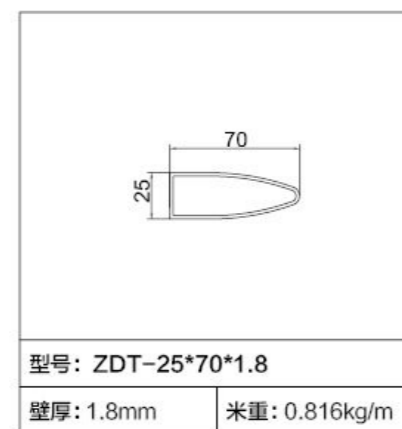
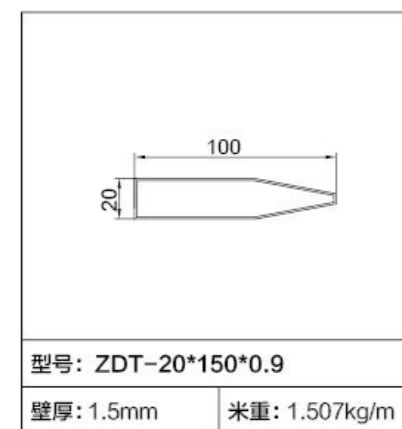
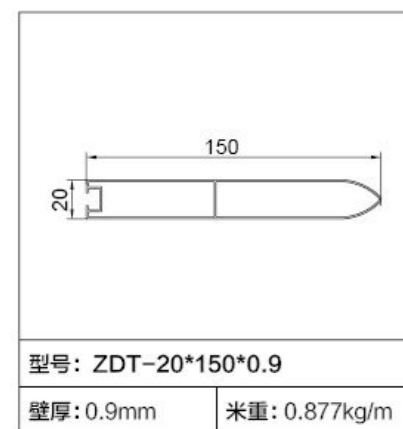
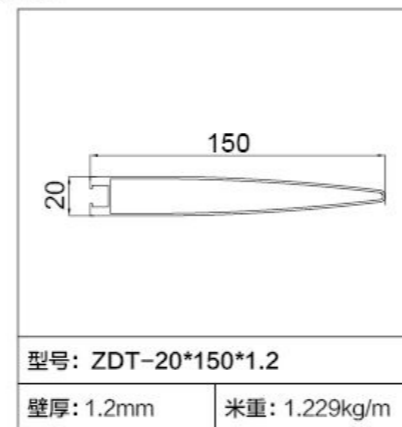

组合管系列

Combined pipe series

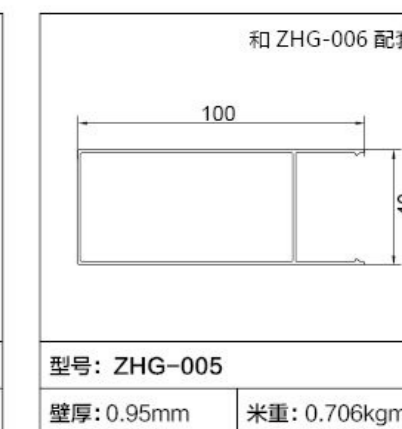
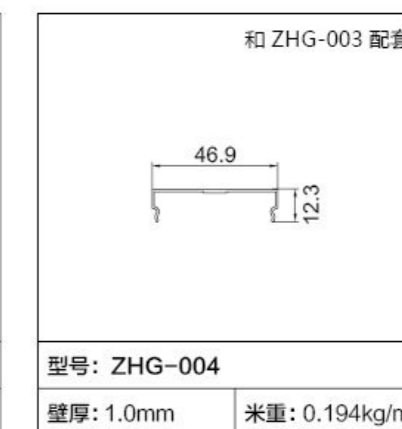
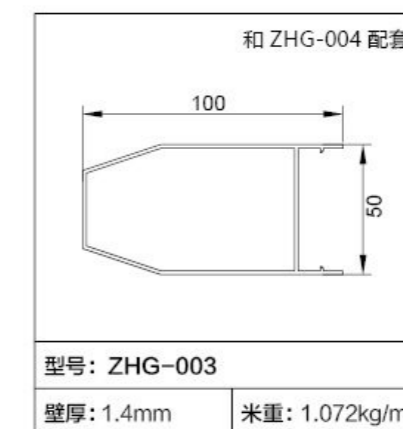
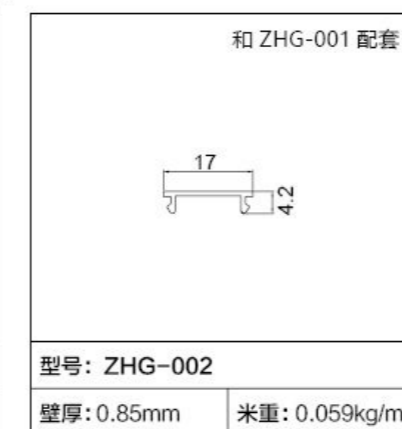
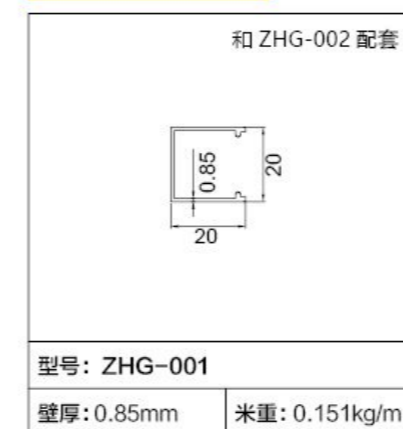



<p>和 ZHG-005 配套</p> <p>型号: ZHG-006 壁厚: 1.0mm 米重: 0.144kg/m</p>	<p>和 ZHG-008 配套</p> <p>型号: ZHG-007 壁厚: 1.3mm 米重: 0.522kg/m</p>	<p>和 ZHG-007 配套</p> <p>型号: ZHG-008 壁厚: 1.3mm 米重: 0.287kg/m</p>	<p>和 ZHG-010 配套</p> <p>型号: ZHG-009 壁厚: 2.0mm 米重: 0.262kg/m</p>	<p>和 ZHG-009 配套</p> <p>型号: ZHG-010 壁厚: 1.5mm 米重: 0.128kg/m</p>	<p>和 ZHG-022 配套</p> <p>型号: ZHG-021 壁厚: 0.75mm 米重: 0.185kg/m</p>	<p>和 ZHG-021 配套</p> <p>型号: ZHG-022 壁厚: *mm 米重: 0.185kg/m</p>	<p>和 ZHG-024 配套</p> <p>型号: ZHG-023 壁厚: 1.45mm 米重: 1.046kg/m</p>	<p>和 ZHG-023 配套</p> <p>型号: ZHG-024 壁厚: *mm 米重: 0.215kg/m</p>	<p>和 ZHG-026 配套</p> <p>型号: ZHG-025 壁厚: 1.15mm 米重: 1.019kg/m</p>
<p>和 ZHG-012 配套</p> <p>型号: ZHG-011 壁厚: 1.2mm 米重: 1.129kg/m</p>	<p>和 ZHG-011 配套</p> <p>型号: ZHG-012 壁厚: 1.2mm 米重: 0.471kg/m</p>	<p>和 ZHG-014 配套</p> <p>型号: ZHG-013 壁厚: 1.0mm 米重: 0.652kg/m</p>	<p>和 ZHG-013 配套</p> <p>型号: ZHG-014 壁厚: 0.9mm 米重: 0.113kg/m</p>	<p>和 ZHG-016 配套</p> <p>型号: ZHG-015 壁厚: 1.0mm 米重: 0.407kg/m</p>	<p>和 ZHG-025 配套</p> <p>型号: ZHG-026 壁厚: 1.15mm 米重: 0.258kg/m</p>	<p>和 ZHG-028 配套</p> <p>型号: ZHG-027 壁厚: 1.15mm 米重: 0.767kg/m</p>	<p>和 ZHG-027 配套</p> <p>型号: ZHG-028 壁厚: 1.45mm 米重: 0.652kg/m</p>	<p>和 ZHG-031 配套</p> <p>型号: ZHG-029 壁厚: 1.0mm 米重: 0.655kg/m</p>	<p>和 ZHG-031 配套</p> <p>型号: ZHG-030 壁厚: 1.0mm 米重: 0.437kg/m</p>
<p>和 ZHG-015 配套</p> <p>型号: ZHG-016 壁厚: 0.9mm 米重: 0.125kg/m</p>	<p>和 ZHG-018 配套</p> <p>型号: ZHG-017 壁厚: 2.0mm 米重: 0.207kg/m</p>	<p>和 ZHG-017 配套</p> <p>型号: ZHG-018 壁厚: 1.2mm 米重: 0.072kg/m</p>	<p>和 ZHG-020 配套</p> <p>型号: ZHG-019 壁厚: 1.0mm 米重: 0.801kg/m</p>	<p>和 ZHG-019 配套</p> <p>型号: ZHG-020 壁厚: 1.0mm 米重: 0.302kg/m</p>	<p>和 ZHG-029 和 ZHG-030 配套</p> <p>型号: ZHG-031 壁厚: 1.0mm 米重: 0.106kg/m</p>	<p>和 ZHG-033 配套</p> <p>型号: ZHG-032 壁厚: 1.4mm 米重: 0.324kg/m</p>	<p>和 ZHG-032 配套</p> <p>型号: ZHG-033 壁厚: *mm 米重: 0.141kg/m</p>	<p>和 ZHG-035 配套</p> <p>型号: ZHG-034 壁厚: 3.0mm 米重: 1.594kg/m</p>	<p>和 ZHG-034 配套</p> <p>型号: ZHG-035 壁厚: 2.5mm 米重: 0.444kg/m</p>

和 ZHG-038 配套

型号: ZHG-036
壁厚: 1.4mm 米重: 1.149kg/m

和 ZHG-037 配套

型号: ZHG-037
壁厚: 1.4mm 米重: 0.768kg/m

和 ZHG-036 和 ZHG-037 配套

型号: ZHG-038
壁厚: 0.8mm 米重: 0.26kg/m

和 ZHG-040 配套

型号: ZHG-039
壁厚: 0.75mm 米重: 0.19kg/m

和 ZHG-040 配套

型号: ZHG-040
壁厚: 0.75mm 米重: 0.09kg/m

和 ZHG-050 配套

型号: ZHG-051
壁厚: *mm 米重: 0.193kg/m

和 ZHG-053 配套

型号: ZHG-052
壁厚: 1.0mm 米重: 0.57kg/m

和 ZHG-052 配套

型号: ZHG-053
壁厚: 0.7mm 米重: 0.114kg/m

和 ZHG-055 配套

型号: ZHG-054
壁厚: 2.0mm 米重: 0.367kg/m

和 ZHG-054 配套

型号: ZHG-055
壁厚: 1.0mm 米重: 0.06kg/m

和 ZHG-043 配套

型号: ZHG-041
壁厚: 1.2mm 米重: 0.71kg/m

和 ZHG-043 配套

型号: ZHG-042
壁厚: 1.2mm 米重: 0.82kg/m

和 ZHG-041 和 ZHG-042 配套

型号: ZHG-043
壁厚: *mm 米重: 0.065kg/m

和 ZHG-045 配套

型号: ZHG-044
壁厚: 0.95mm 米重: 0.312kg/m

和 ZHG-044 配套

型号: ZHG-045
壁厚: 0.95mm 米重: 0.184kg/m

和 ZHG-057 配套

型号: ZHG-056
壁厚: 0.7mm 米重: 0.203kg/m

和 ZHG-056 配套

型号: ZHG-057
壁厚: 0.7mm 米重: 0.075kg/m

和 ZHG-059 配套

型号: ZHG-058
壁厚: 1.1mm 米重: 0.749kg/m

和 ZHG-058 配套

型号: ZHG-059
壁厚: 1.1mm 米重: 0.358kg/m

和 ZHG-061 配套

型号: ZHG-060
壁厚: 1.5mm 米重: 0.466kg/m

和 ZHG-047 配套

型号: ZHG-046
壁厚: 0.9mm 米重: 0.753kg/m

和 ZHG-046 配套

型号: ZHG-047
壁厚: 0.9mm 米重: 0.194kg/m

和 ZHG-049 配套

型号: ZHG-048
壁厚: *mm 米重: 0.089kg/m

和 ZHG-048 配套

型号: ZHG-049
壁厚: 1.4mm 米重: 0.522kg/m

和 ZHG-051 配套

型号: ZHG-050
壁厚: 1.2mm 米重: 0.83kg/m

和 ZHG-060 配套

型号: ZHG-061
壁厚: 1.2mm 米重: 0.113kg/m

和 ZHG-063 配套

型号: ZHG-062
壁厚: 1.4mm 米重: 1.067kg/m

和 ZHG-062 配套





型号: ZHG-063
壁厚: 1.2mm 米重: 0.352kg/m

和 ZHG-065 配套

型号: ZHG-064
壁厚: 1.0mm 米重: 0.287kg/m

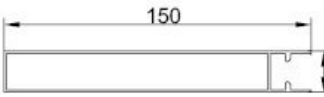
和 ZHG-064 配套

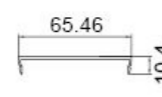
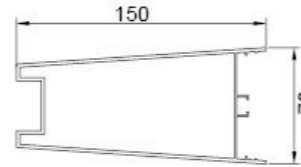
型号: ZHG-065
壁厚: 1.0mm 米重: 0.15kg/m

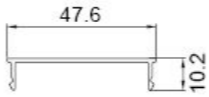
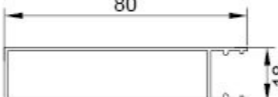
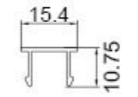
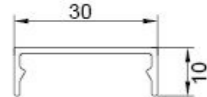
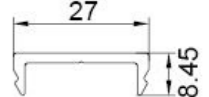
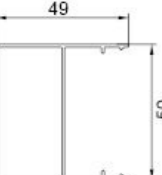
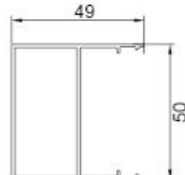
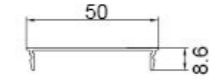
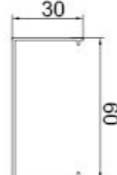
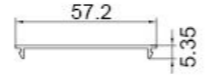
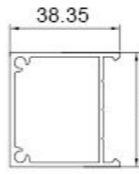
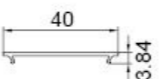
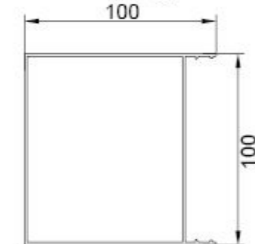
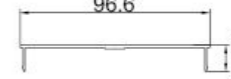
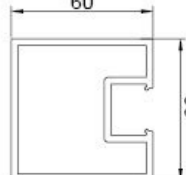
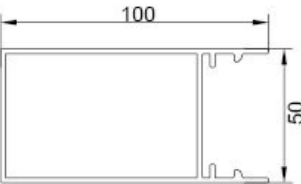
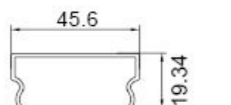
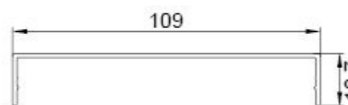
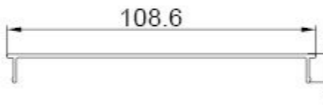
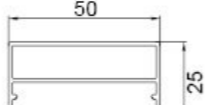
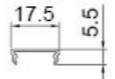
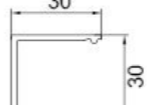
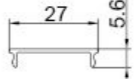
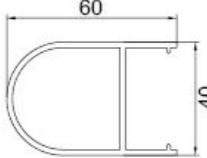
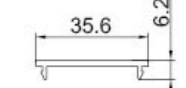
<p>和 ZHG-067 配套</p>  <p>型号: ZHG-066 壁厚: 1.1mm 米重: 1.057kg/m</p>	<p>和 ZHG-066 配套</p>  <p>型号: ZHG-067 壁厚: 1.0mm 米重: 0.175kg/m</p>	<p>和 ZHG-069 配套</p>  <p>型号: ZHG-068 壁厚: 2.0mm 米重: 0.402kg/m</p>	<p>和 ZHG-068 配套</p>  <p>型号: ZHG-069 壁厚: 1.9mm 米重: 2.275kg/m</p>	<p>和 ZHG-073 配套</p>  <p>型号: ZHG-070 壁厚: 1.2mm 米重: 0.968kg/m</p>	<p>和 ZHG-080 配套</p>  <p>型号: ZHG-081 壁厚: 1.2mm 米重: 0.211kg/m</p>	<p>和 ZHG-083 配套</p>  <p>型号: ZHG-082 壁厚: 1.1mm 米重: 0.592kg/m</p>	<p>和 ZHG-082 配套</p>  <p>型号: ZHG-083 壁厚: 1.1mm 米重: 0.101kg/m</p>	<p>和 ZHG-085 配套</p>  <p>型号: ZHG-084 壁厚: 1.2mm 米重: 0.165kg/m</p>	<p>和 ZHG-084 配套</p>  <p>型号: ZHG-085 壁厚: 2.0mm 米重: 0.206kg/m</p>
<p>和 ZHG-073 配套</p>  <p>型号: ZHG-071 壁厚: 1.0mm 米重: 0.548kg/m</p>	<p>和 ZHG-073 配套</p>  <p>型号: ZHG-072 壁厚: 1.2mm 米重: 0.641kg/m</p>	<p>和 ZHG-070/071/072 配套</p>  <p>型号: ZHG-073 壁厚: 1.0mm 米重: 0.189kg/m</p>	<p>和 ZHG-075 配套</p>  <p>型号: ZHG-074 壁厚: 1.2mm 米重: 0.398kg/m</p>	<p>和 ZHG-074 配套</p>  <p>型号: ZHG-075 壁厚: 1.2mm 米重: 0.217kg/m</p>	<p>和 ZHG-087 配套</p>  <p>型号: ZHG-086 壁厚: *mm 米重: 0.691kg/m</p>	<p>和 ZHG-086 配套</p>  <p>型号: ZHG-087 壁厚: 1.2mm 米重: 0.144kg/m</p>	<p>和 ZHG-089 配套</p>  <p>型号: ZHG-088 壁厚: 1.5mm 米重: 1.633kg/m</p>	<p>和 ZHG-088 配套</p>  <p>型号: ZHG-089 壁厚: 1.5mm 米重: 0.469kg/m</p>	<p>和 ZHG-091 配套</p>  <p>型号: ZHG-090 壁厚: 2.9mm 米重: 2.12kg/m</p>
<p>和 ZHG-077 配套</p>  <p>型号: ZHG-076 壁厚: 1.9mm 米重: 1.572kg/m</p>	<p>和 ZHG-076 配套</p>  <p>型号: ZHG-077 壁厚: *mm 米重: 0.301kg/m</p>	<p>和 ZHG-079 配套</p>  <p>型号: ZHG-078 壁厚: 1.5mm 米重: 0.589kg/m</p>	<p>和 ZHG-078 配套</p>  <p>型号: ZHG-079 壁厚: 1.2mm 米重: 0.407kg/m</p>	<p>和 ZHG-081 配套</p>  <p>型号: ZHG-080 壁厚: 1.2mm 米重: 0.493kg/m</p>	<p>和 ZHG-090 配套</p>  <p>型号: ZHG-091 壁厚: 0.8mm 米重: 0.066kg/m</p>	<p>和 ZHG-093 配套</p>  <p>型号: ZHG-092 壁厚: 1.85mm 米重: 0.433kg/m</p>	<p>和 ZHG-092 配套</p>  <p>型号: ZHG-093 壁厚: 1.0mm 米重: 0.103kg/m</p>	<p>和 ZHG-095 配套</p>  <p>型号: ZHG-094 壁厚: 2.0mm 米重: 0.973kg/m</p>	<p>和 ZHG-094 配套</p>  <p>型号: ZHG-095 壁厚: 2.0mm 米重: 0.222kg/m</p>

组合管系列

Combined pipe series



优选材料



精工制作



钻石品质

水滴挂片系列

Water drop hanging plate series

和 ZHG-097 配套

型号: ZHG-096
壁厚: 1.2mm 米重: 0.584kg/m

和 ZHG-096 配套

型号: ZHG-097
壁厚: 1.2mm 米重: 0.145kg/m

和 ZHG-099 配套

型号: ZHG-098
壁厚: 1.5mm 米重: 1.365kg/m

和 ZHG-098 配套

型号: ZHG-099
壁厚: 1.2mm 米重: 0.245kg/m

和 ZHG-101 配套

型号: ZHG-100
壁厚: 0.9mm 米重: 0.33kg/m

型号: DSGP-7*100*1.35
壁厚: 1.35mm 米重: 0.386kg/m

型号: DSGP-20*100*0.8
壁厚: 0.8mm 米重: 0.401kg/m

型号: DSGP-20*100*1.0
壁厚: 1.0mm 米重: 0.498kg/m

型号: DSGP-25*70*0.8
壁厚: 0.8mm 米重: 0.345kg/m

型号: DSGP-25*80*0.8
壁厚: 0.8mm 米重: 0.367kg/m

和 ZHG-100 配套

型号: ZHG-101
壁厚: 0.9mm 米重: 0.25kg/m

和 ZHG-103 配套

型号: ZHG-102
壁厚: 1.3mm 米重: 0.46kg/m

和 ZHG-102 配套

型号: ZHG-103
壁厚: *mm 米重: 0.805kg/m

和 ZHG-105 配套

型号: ZHG-104
壁厚: 0.95mm 米重: 0.387kg/m

和 ZHG-104 配套

型号: ZHG-105
壁厚: 0.95mm 米重: 0.124kg/m

型号: DSGP-25*100*0.8
壁厚: 0.8mm 米重: 0.426kg/m

型号: DSGP-25*120*1.0
壁厚: 1.0mm 米重: 0.605kg/m

型号: DSGP-25*150*1.1
壁厚: 1.1mm 米重: 0.637kg/m

型号: DSGP-25*150*1.5
壁厚: 1.2mm 米重: 0.732kg/m

型号: DSGP-35*99.88*0.75
壁厚: 0.75mm 米重: 0.395kg/m

型号: ZHG-106
壁厚: 1.8mm 米重: 1.286kg/m

型号: ZHG-107
壁厚: *mm 米重: 0.26kg/m

型号: ZHG-108
壁厚: 2.9mm 米重: 0.325kg/m

型号: ZHG-109
壁厚: *mm 米重: 1.809kg/m

型号: ZHG-110
壁厚: *mm 米重: 0.34kg/m

型号: DSGP-35*150*1.35
壁厚: 1.35mm 米重: 0.855kg/m

型号: DSGP-50*120*0.9
壁厚: 0.9mm 米重: 0.66kg/m

型号: DSGP-50*150*1.1
壁厚: 1.1mm 米重: 0.965kg/m

型号:
壁厚: 米重:

型号:
壁厚: 米重:



优选材料



精工制作



钻石品质

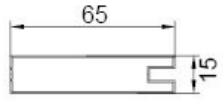

型号: DCG-001	
壁厚: 0.65mm	米重: 0.313kg/m



型号: DCG-002	
壁厚: 0.65mm	米重: 0.291kg/m



型号: DCG-003	
壁厚: 1.0mm	米重: 0.223kg/m



型号: DCG-004	
壁厚: 1.5mm	米重: 0.487kg/m



型号: DCG-005	
壁厚: 0.9mm	米重: 0.406kg/m

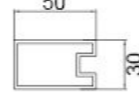

型号: DCG-016	
壁厚: 2.0mm	米重: 0.935kg/m

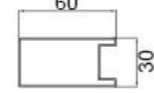

型号: DCG-017	
壁厚: 0.85mm	米重: 0.453kg/m

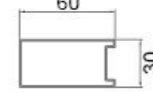

型号: DCG-018	
壁厚: 0.9mm	米重: 0.46kg/m



型号: DCG-019	
壁厚: 1.5mm	米重: 0.892kg/m



型号: DCG-020	
壁厚: 0.65mm	米重: 0.366kg/m

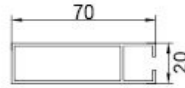

型号: DCG-006	
壁厚: 1.4mm	米重: 0.707kg/m

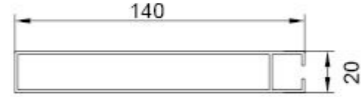

型号: DCG-007	
壁厚: 1.4mm	米重: 1.243kg/m



型号: DCG-008	
壁厚: 1.5mm	米重: 1.507kg/m



型号: DCG-009	
壁厚: 0.9mm	米重: 0.409kg/m



型号: DCG-010	
壁厚: 1.2mm	米重: 0.637kg/m

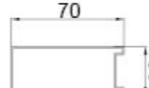

型号: DCG-021	
壁厚: 1.2mm	米重: 0.67kg/m

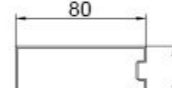

型号: DCG-022	
壁厚: 1.0mm	米重: 0.612kg/m

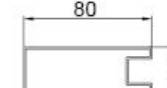

型号: DCG-023	
壁厚: 1.1mm	米重: 0.735kg/m



型号: DCG-024	
壁厚: 1.5mm	米重: 1.736kg/m



型号: DCG-025	
壁厚: 1.5mm	米重: 0.792kg/m



型号: DCG-011	
壁厚: 1.2mm	米重: 0.525kg/m



型号: DCG-012	
壁厚: 1.35mm	米重: 0.495kg/m

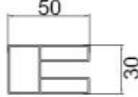

型号: DCG-013	
壁厚: 1.05mm	米重: 0.662kg/m



型号: DCG-014	
壁厚: 1.2mm	米重: 0.64kg/m

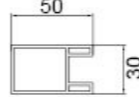

型号: DCG-015	
壁厚: 1.8mm	米重: 0.931kg/m



型号: DCG-026	
壁厚: 1.5mm	米重: 0.753kg/m

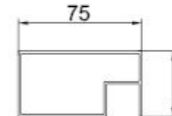

型号: DCG-027	
壁厚: 1.5mm	米重: 0.996kg/m

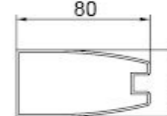

型号: DCG-028	
壁厚: 1.45mm	米重: 0.945kg/m

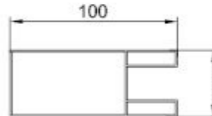

型号: DCG-029	
壁厚: 1.1mm	米重: 1.055kg/m

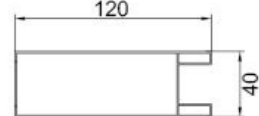

型号: DCG-030	
壁厚: 0.95mm	米重: 0.946kg/m

单凹槽方管

Single-groove square tube



优选材料



精工制作



钻石品质

单凹槽方管

Single-groove square tube

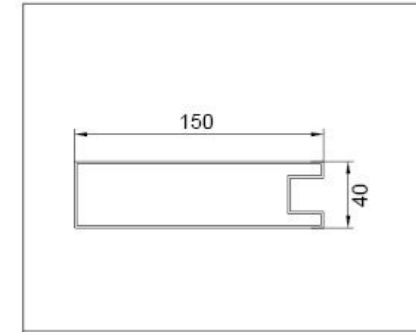
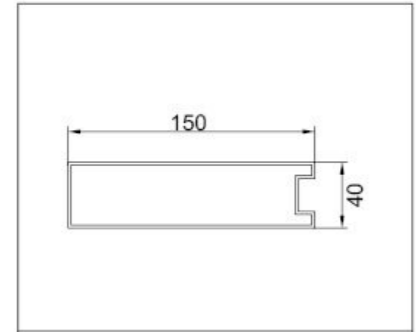
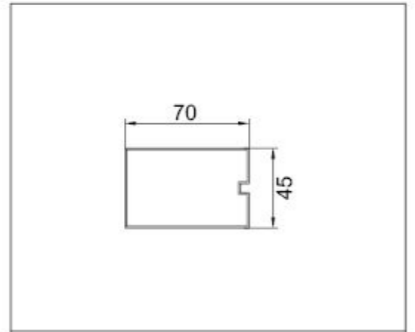
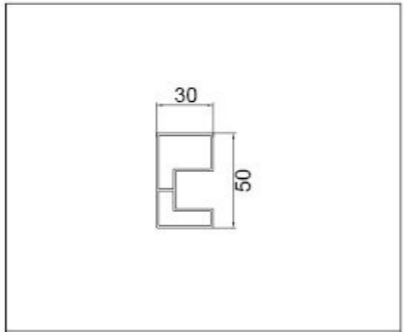
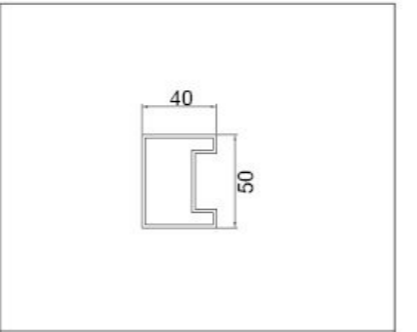
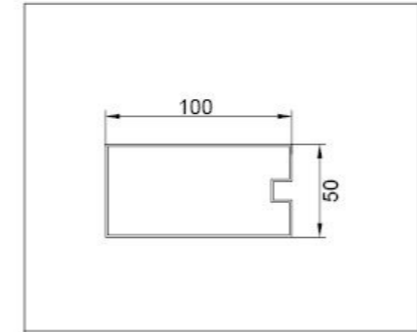
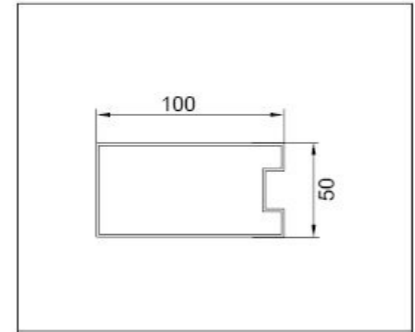
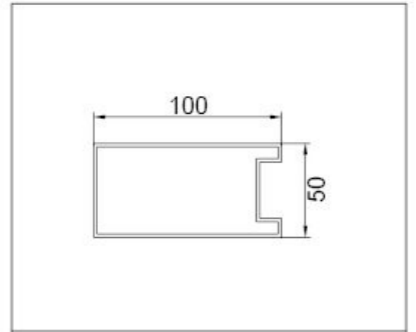
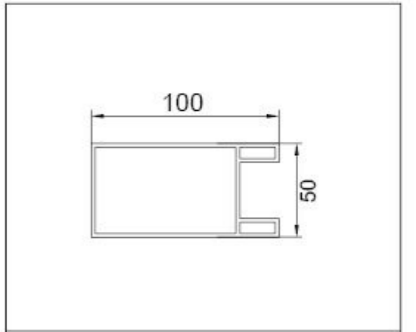
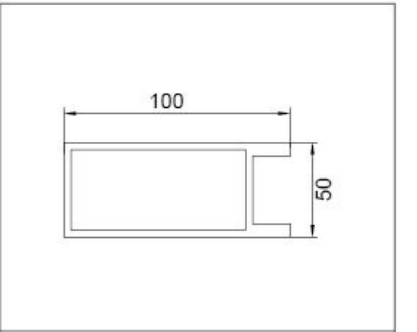
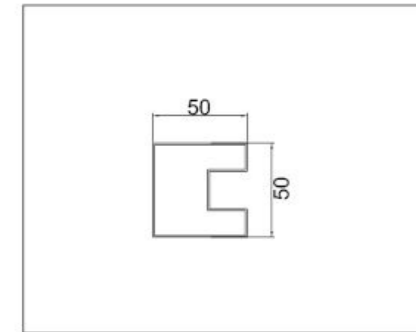
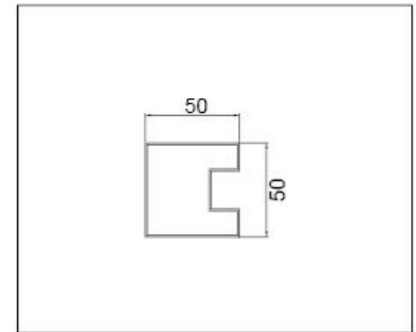
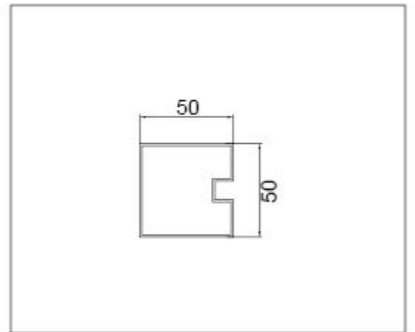
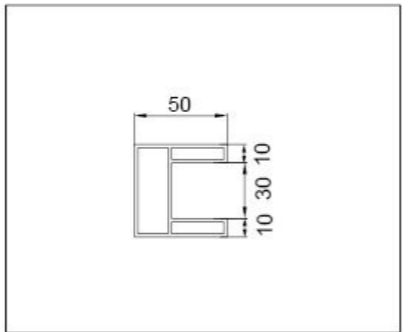
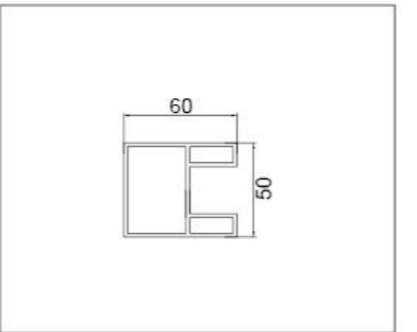
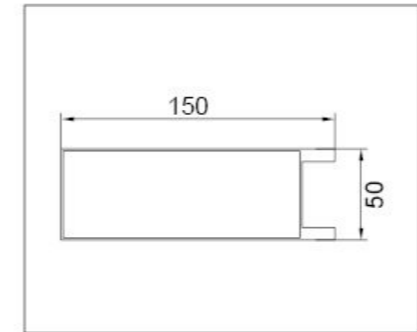
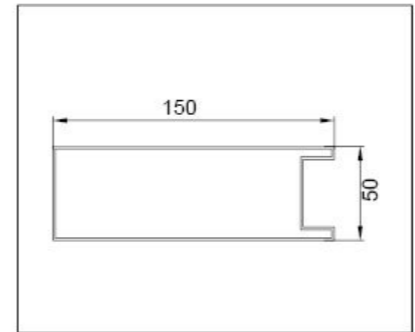
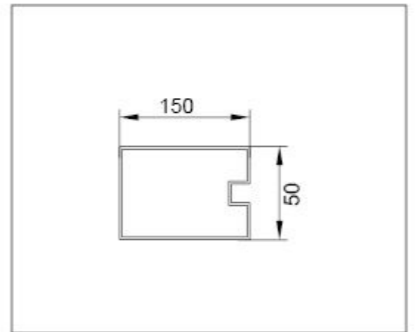
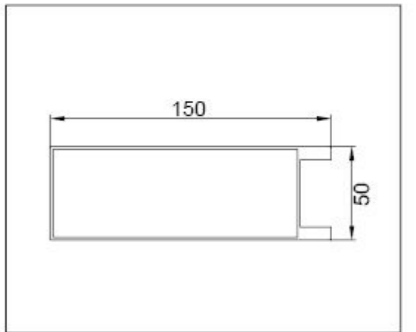
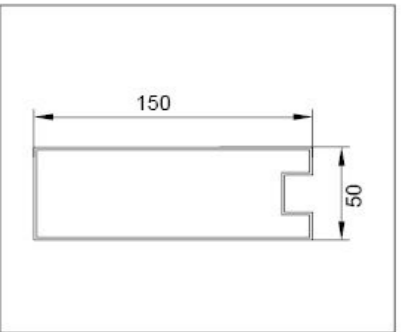
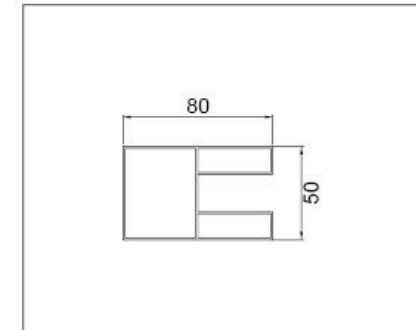
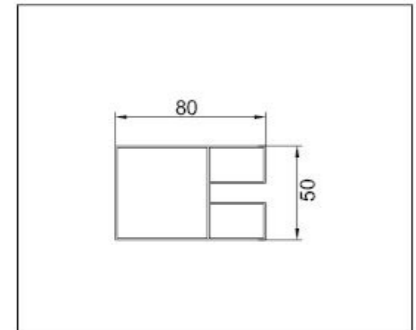
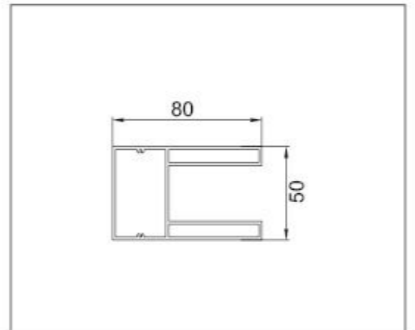
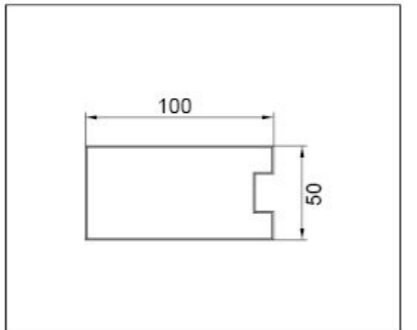
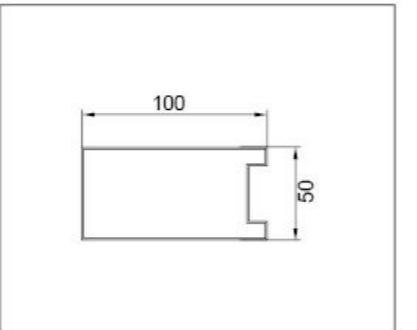
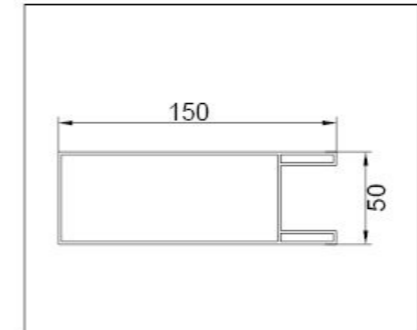
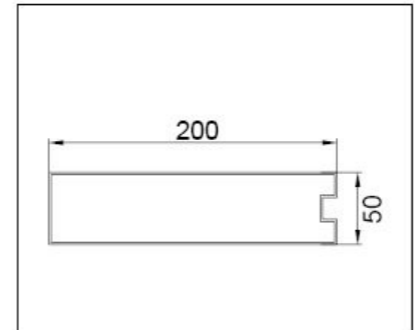
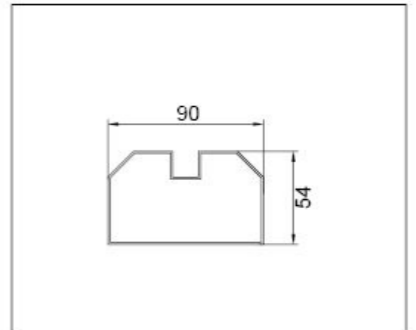
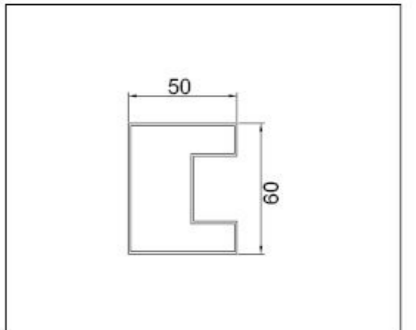
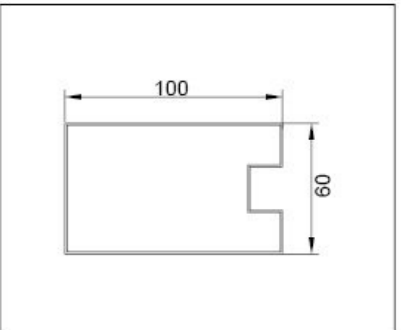
									
型号: DCG-031 壁厚: 1.5mm 米重: 1.695kg/m	型号: DCG-032 壁厚: 1.8mm 米重: 1.916kg/m	型号: DCG-033 壁厚: 0.9mm 米重: 0.577kg/m	型号: DCG-034 壁厚: 1.15mm 米重: 0.635kg/m	型号: DCG-035 壁厚: 1.8mm 米重: 0.959kg/m	型号: DCG-046 壁厚: 1.2mm 米重: 1.025kg/m	型号: DCG-047 壁厚: 1.4mm 米重: 1.201kg/m	型号: DCG-048 壁厚: 1.8mm 米重: 1.546kg/m	型号: DCG-049 壁厚: 2.0mm 米重: 1.889kg/m	型号: DCG-050 壁厚: 3.7mm 米重: 3.647kg/m
									
型号: DCG-036 壁厚: 0.9mm 米重: 0.579kg/m	型号: DCG-037 壁厚: 1.0mm 米重: 0.616kg/m	型号: DCG-038 壁厚: 1.2mm 米重: 0.7kg/m	型号: DCG-039 壁厚: 1.8mm 米重: 1.305kg/m	型号: DCG-040 壁厚: 2.0mm 米重: 1.518kg/m	型号: DCG-051 壁厚: 1.2mm 米重: 1.442kg/m	型号: DCG-052 壁厚: 1.3mm 米重: 1.519kg/m	型号: DCG-053 壁厚: 1.4mm 米重: 0.972kg/m	型号: DCG-054 壁厚: 1.5mm 米重: 1.507kg/m	型号: DCG-055 壁厚: 1.5mm 米重: 1.736kg/m
									
型号: DCG-041 壁厚: 1.1mm 米重: 1.084kg/m	型号: DCG-042 壁厚: 1.2mm 米重: 1.062kg/m	型号: DCG-043 壁厚: 1.5mm 米重: 1.528kg/m	型号: DCG-044 壁厚: 0.8mm 米重: 0.691kg/m	型号: DCG-045 壁厚: 1.0mm 米重: 0.863kg/m	型号: DCG-056 壁厚: 1.55mm 米重: 1.948kg/m	型号: DCG-057 壁厚: 1.6mm 米重: 2.243kg/m	型号: DCG-058 壁厚: 1.2mm 米重: 0.966kg/m	型号: DCG-059 壁厚: 1.1mm 米重: 0.765kg/m	型号: DCG-060 壁厚: 0.9mm 米重: 0.845kg/m

单凹槽方管

Single-groove square tube



优选材料



精工制作



钻石品质

双凹槽方管系列

Double-groove square tube series

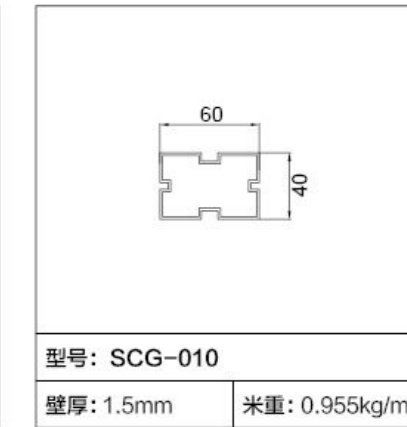
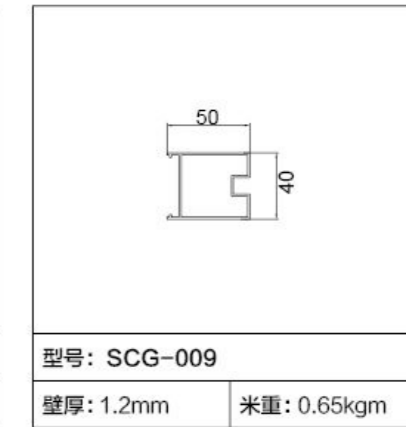
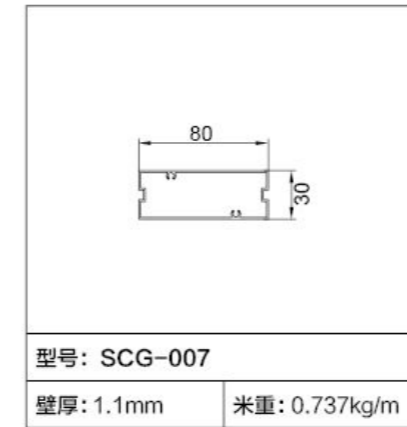
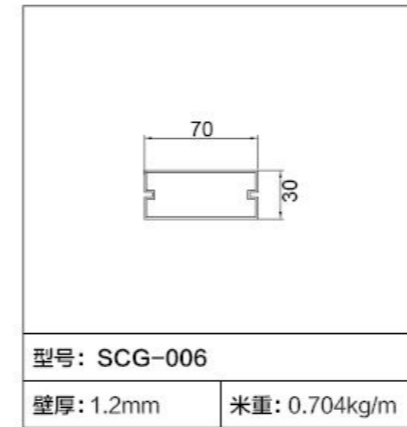
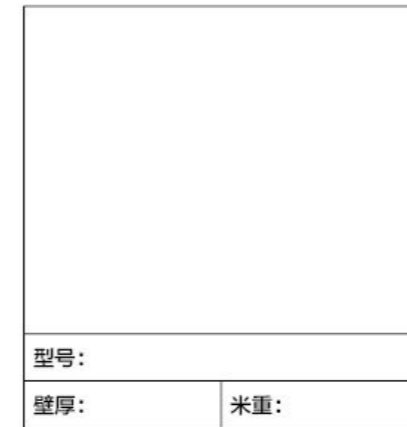
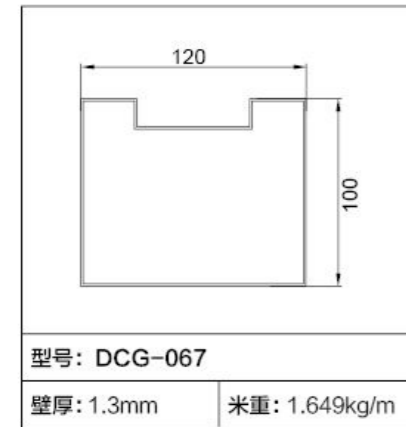
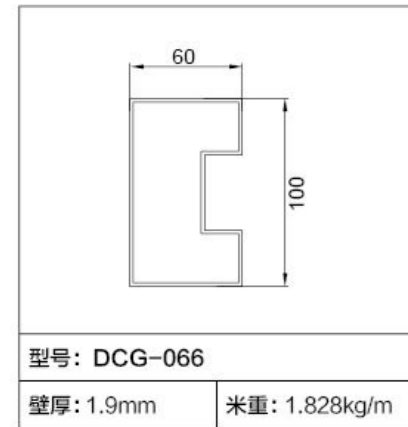
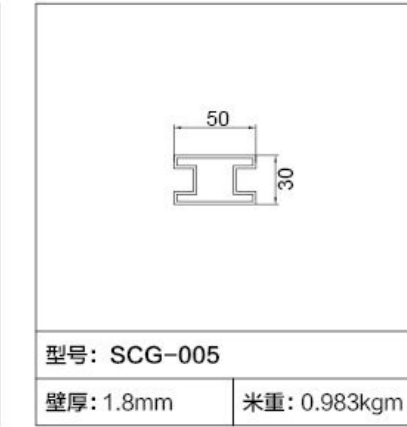
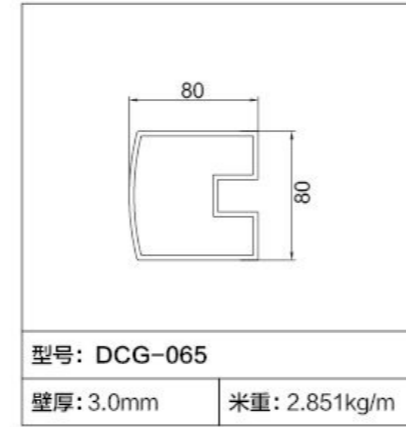
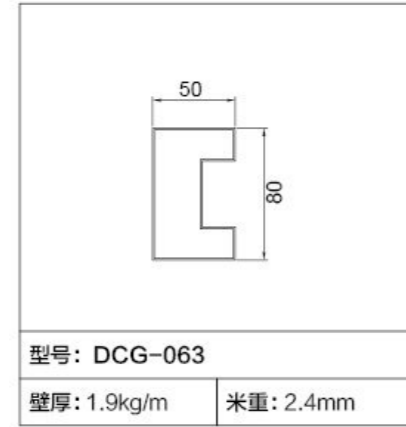
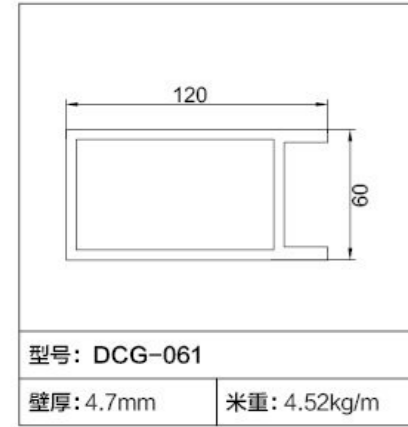

时 / 尚 / 典 / 雅

SIMPLE AND ELEGANT

简约的设计融合经典的生活理念，精湛绝伦的工艺蕴含着时代的气息。留在心中的那一种执着，只为送你梦想成真的惊喜。

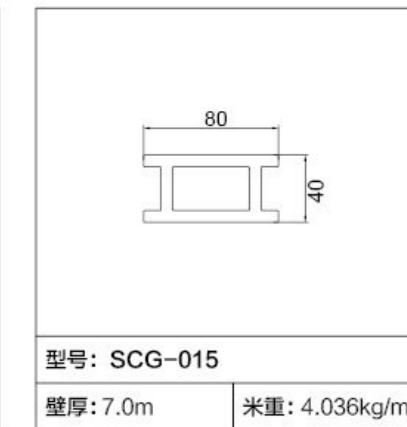
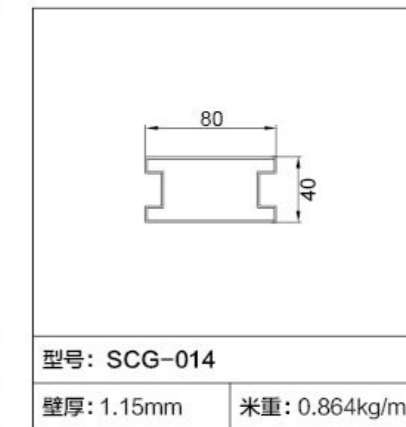
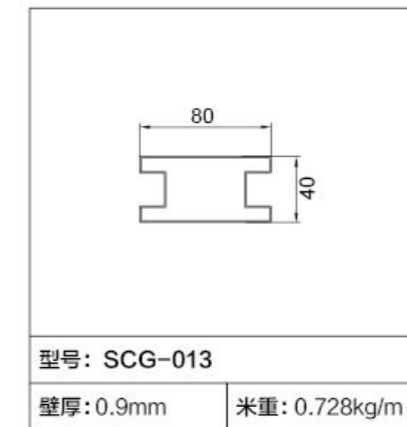
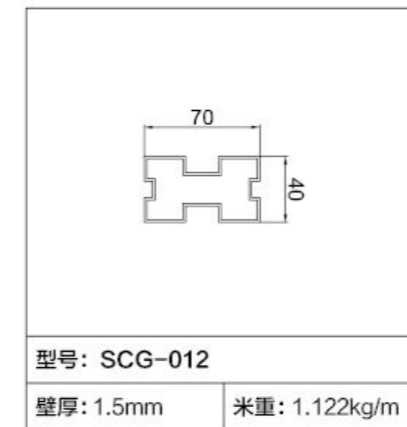

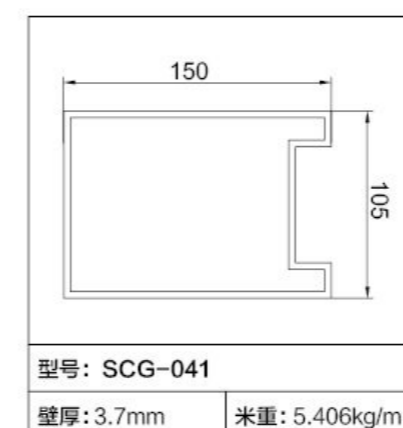
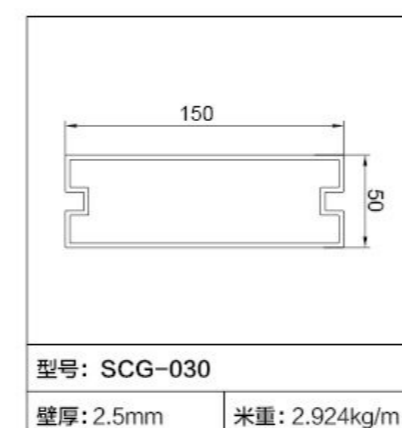
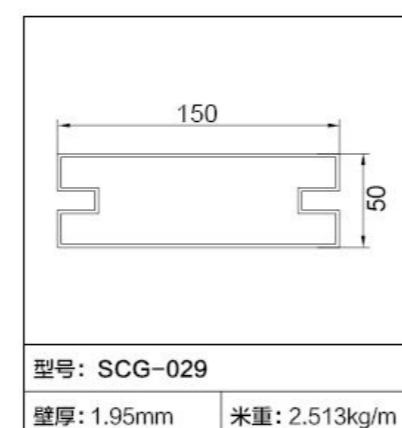
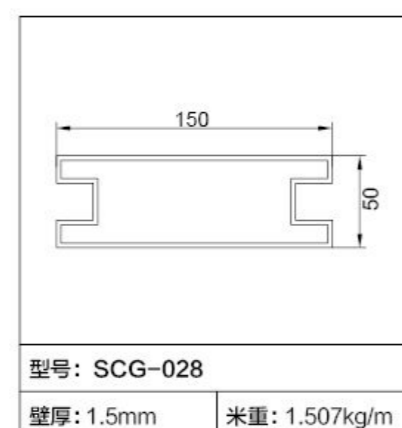
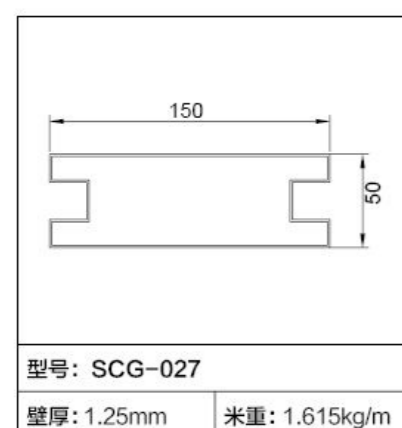
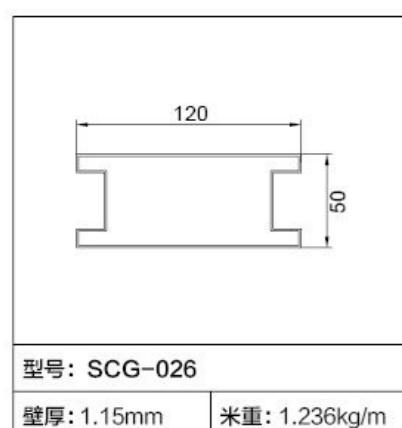
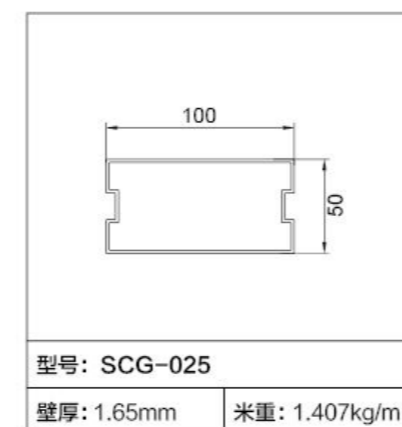
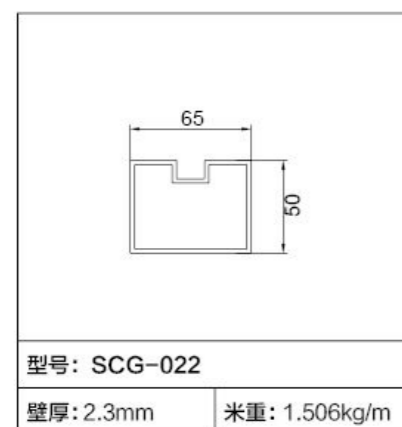
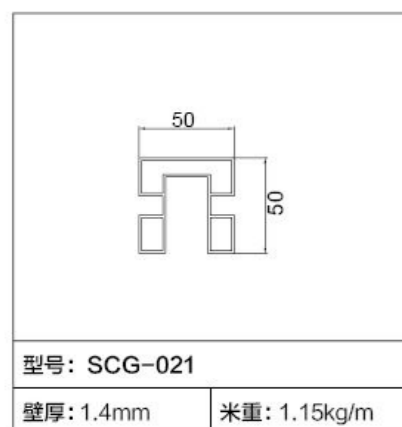
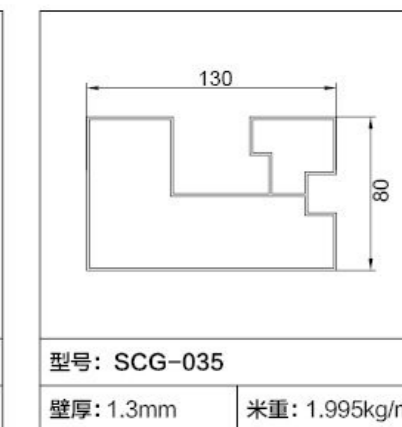
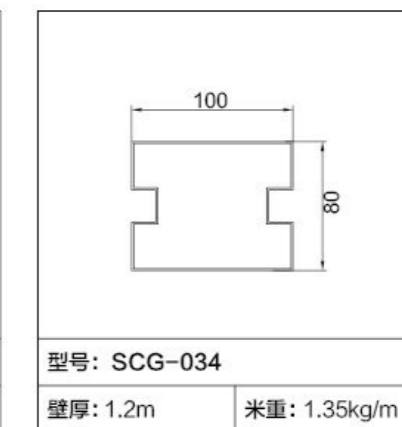
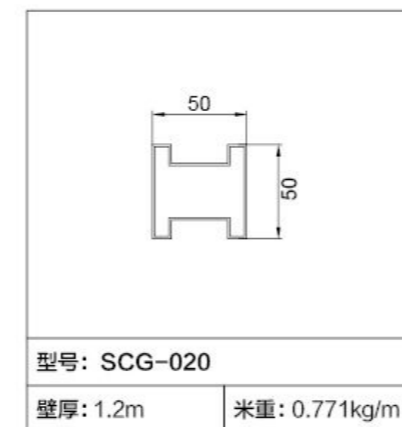
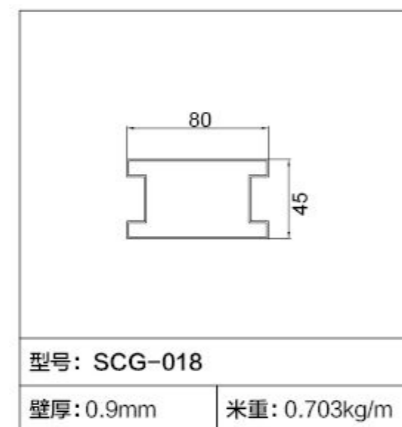
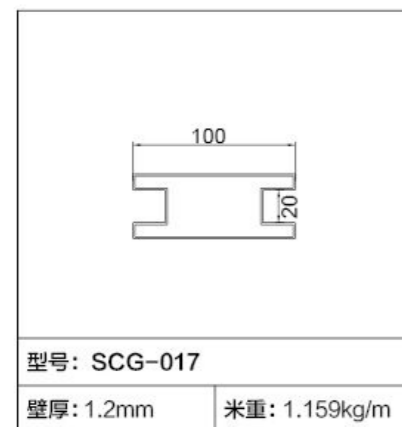
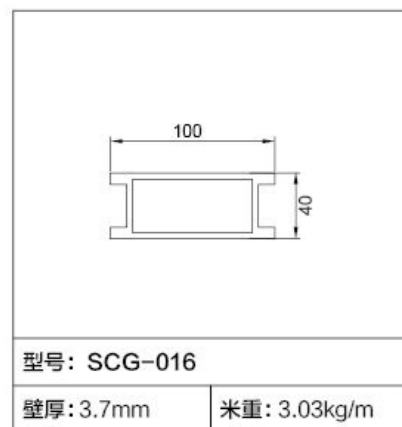

 生活美学
 安全耐用
 健康环保
 款式新颖
 工艺领先

安全·环保·时尚·倡导者

SAFE. ENVIRONMENTALLY FRIENDLY. FASHIONABLE. ADVOCATE

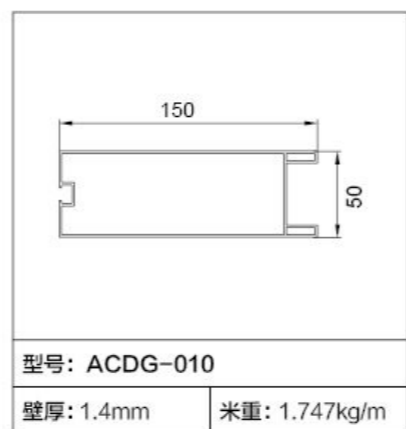
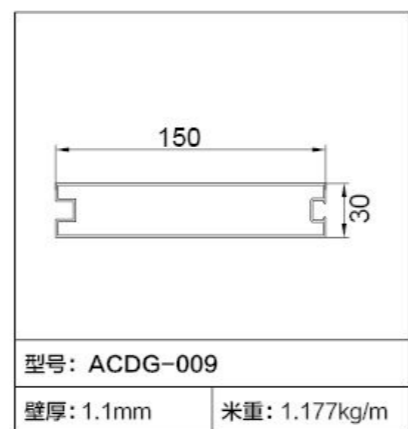
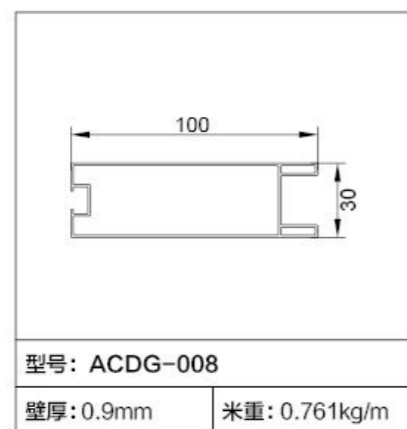
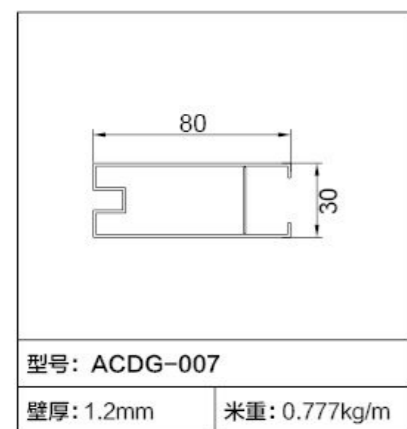
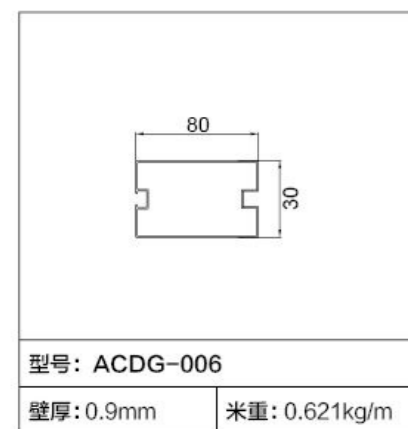
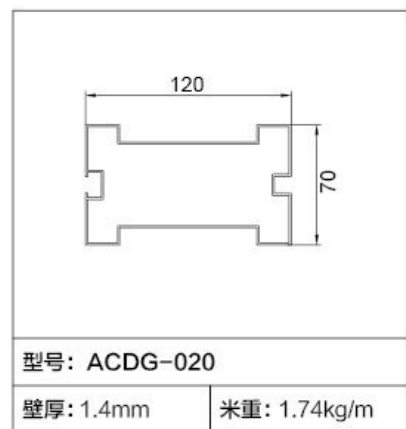
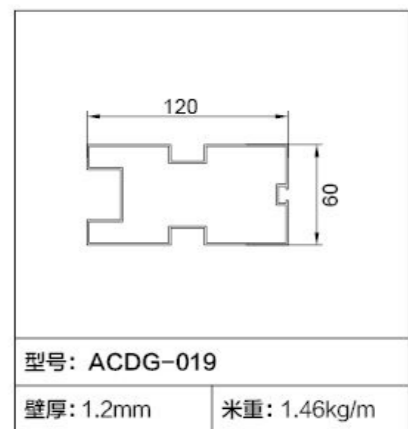
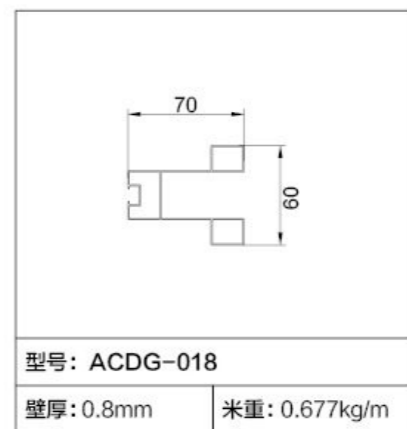
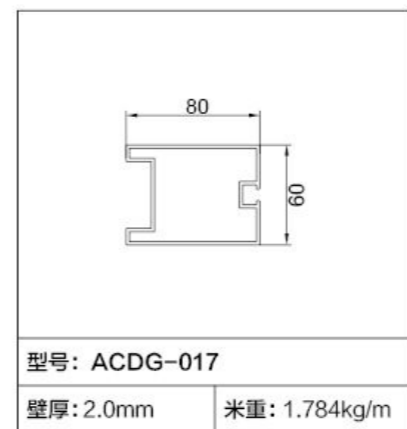
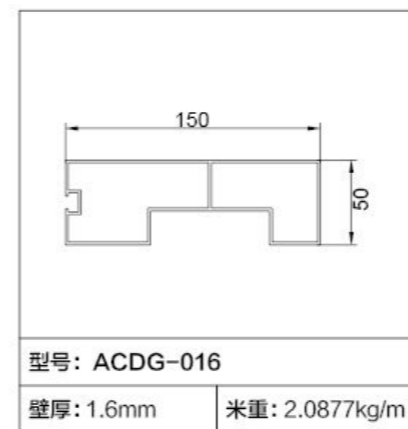
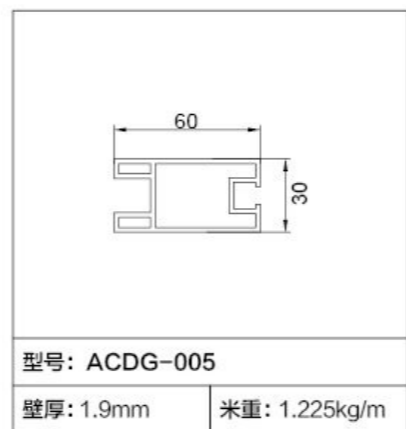
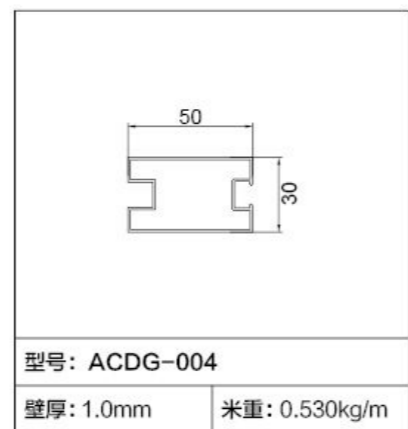
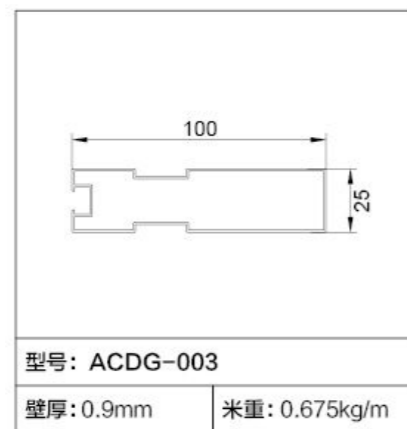
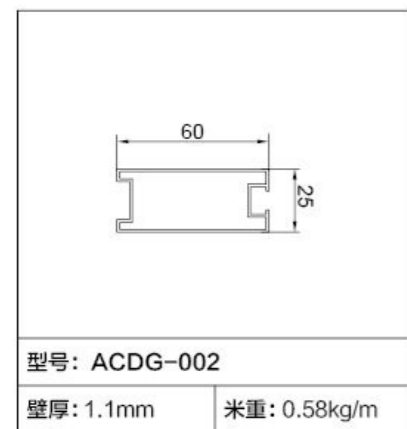
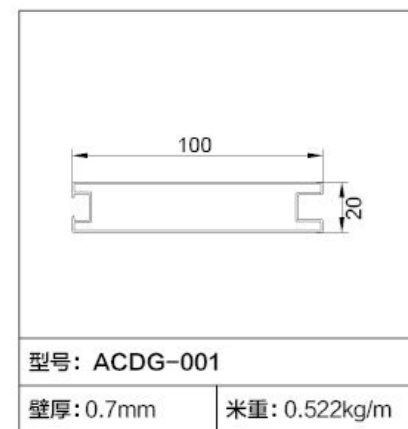

百叶片系列
Hundred-blade series

品位缔造家
完 / 美 / 思 / 维 · 缔 / 造 / 优 / 越 / 生 / 活

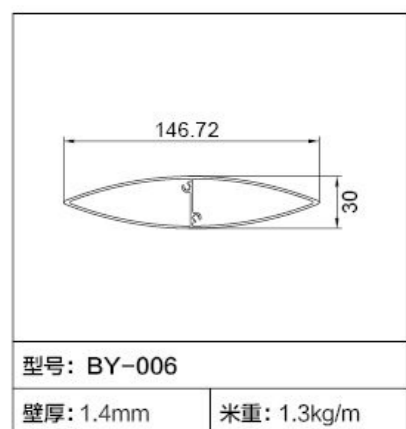
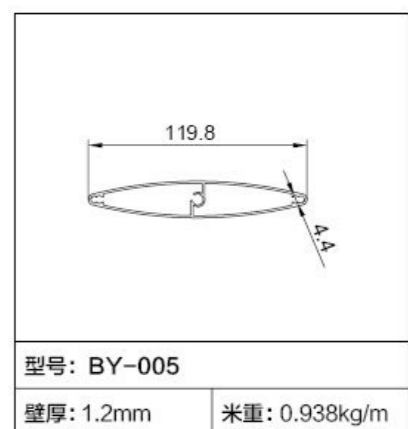
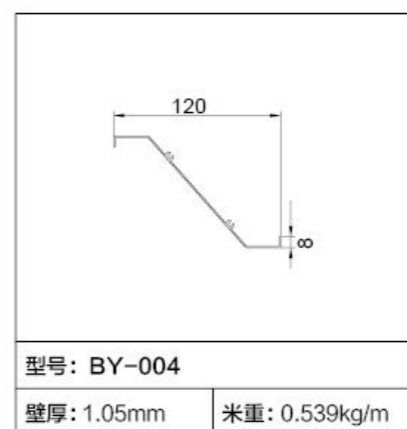
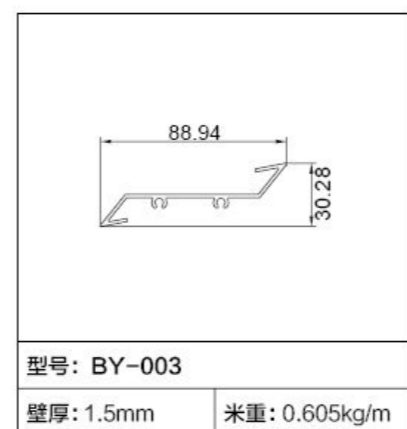
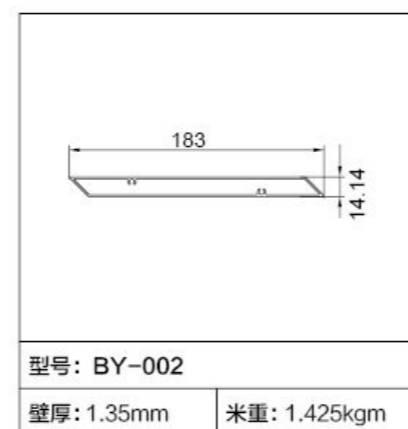
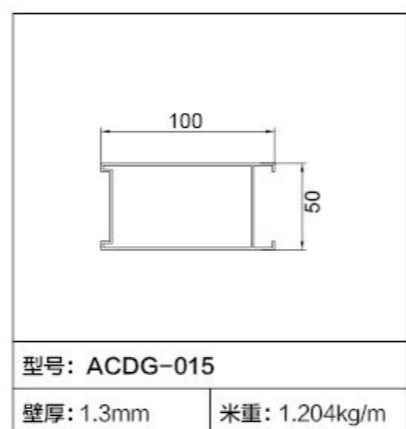
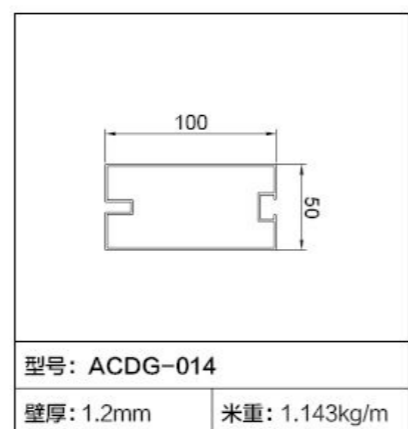
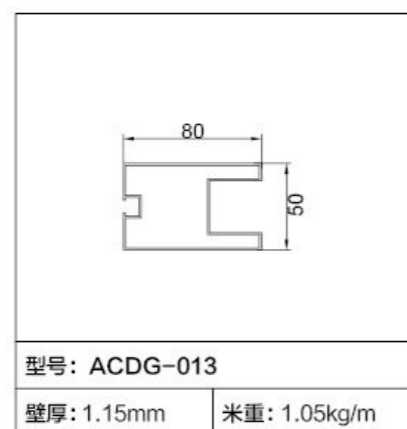
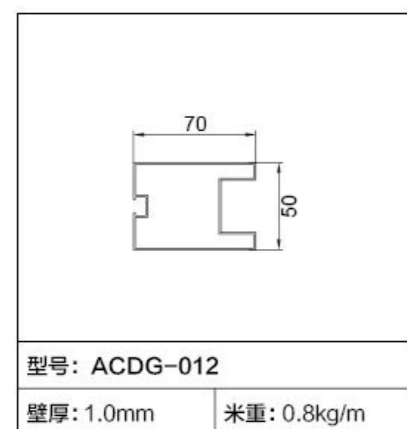
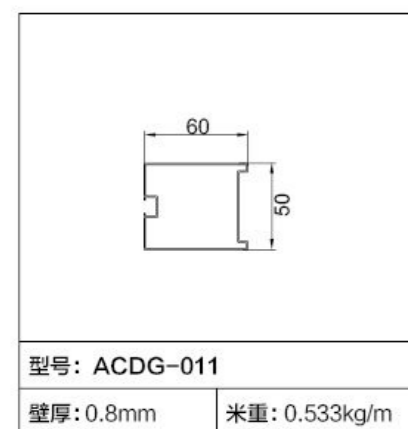
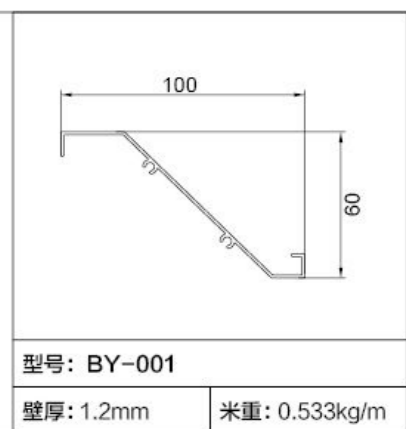

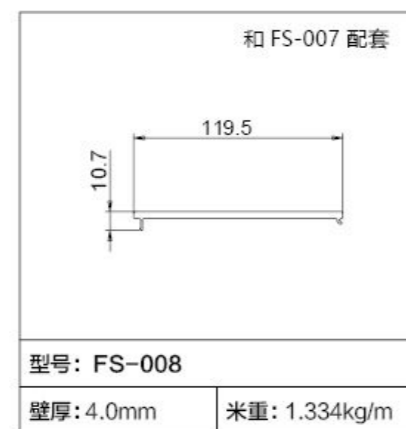
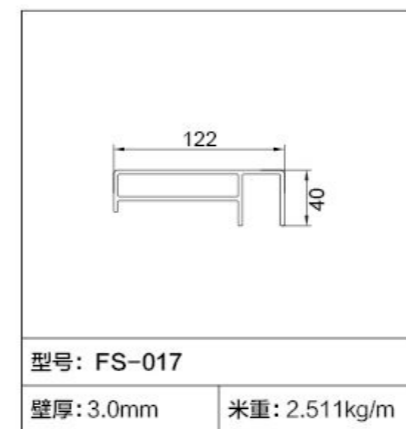
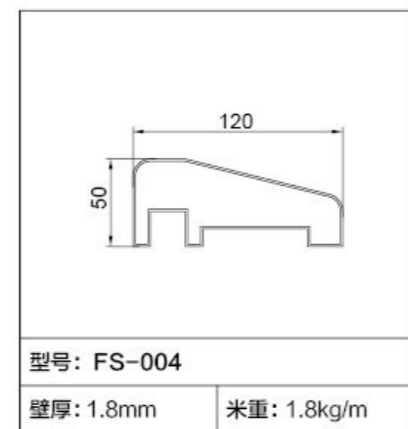
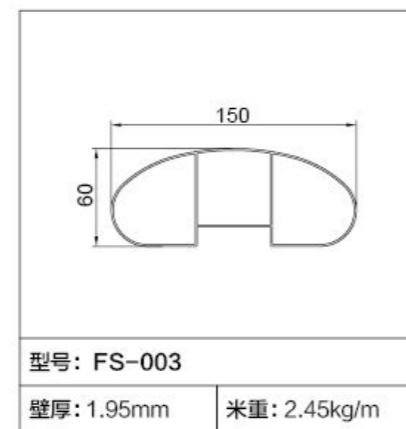
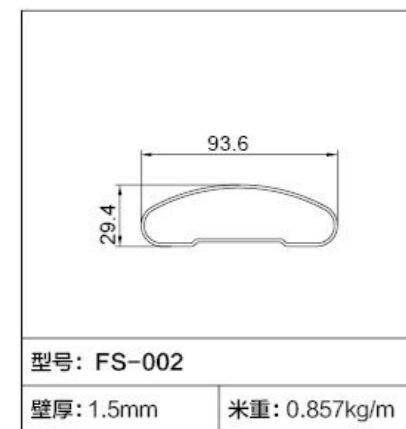

封口盖系列 Sealing cover series

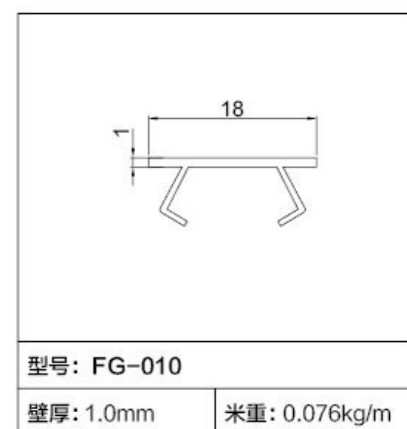
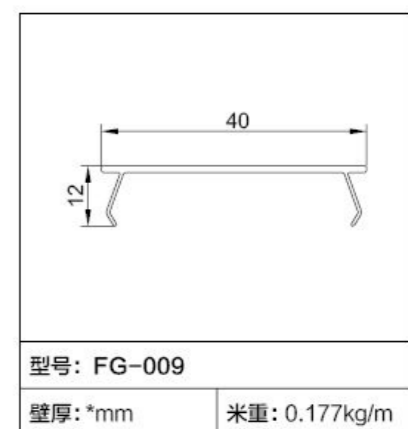
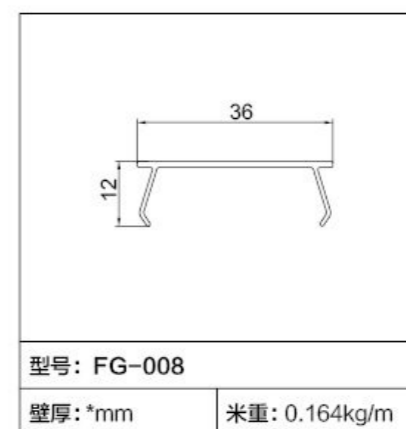
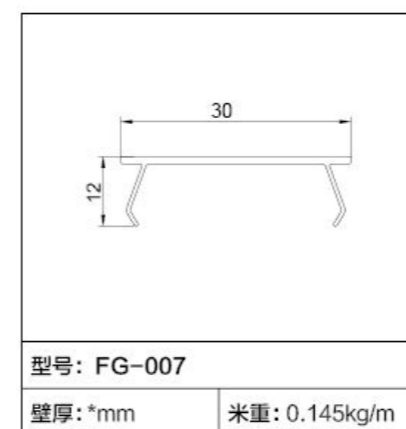
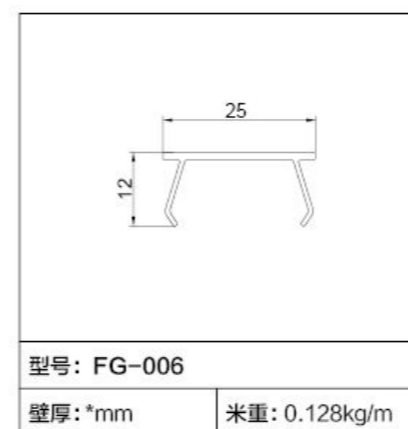
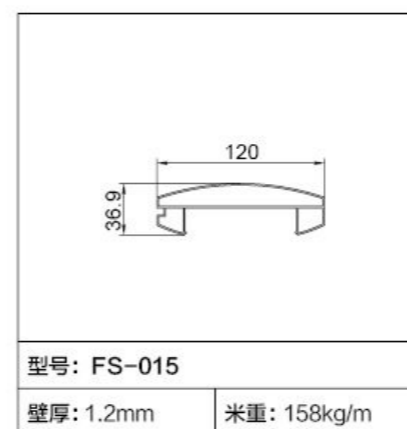
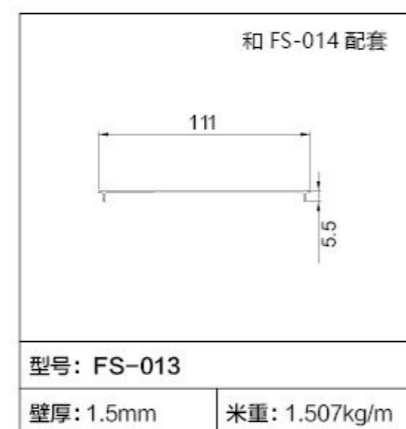
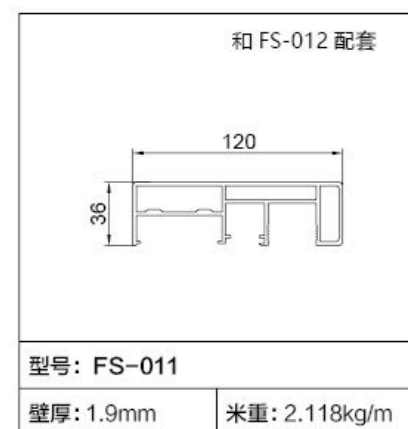
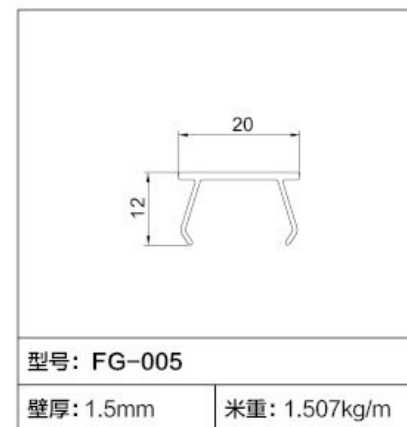
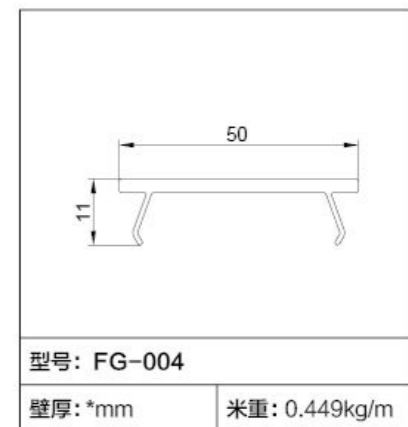
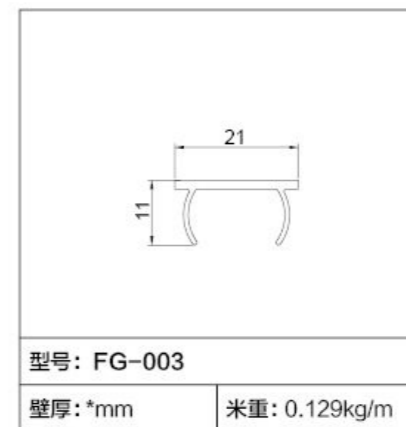
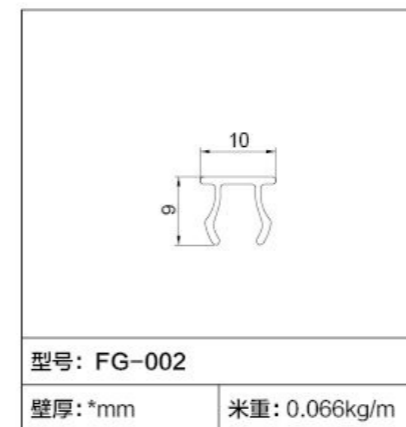

封口盖系列

Sealing cover series

优选材料 精工制作 钻石品质

椭圆管 / 半圆管系列

Elliptical tube/semi-circular tube series

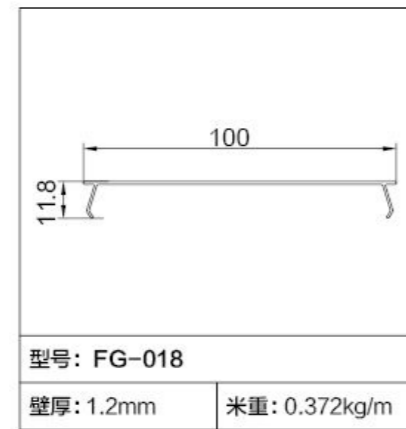
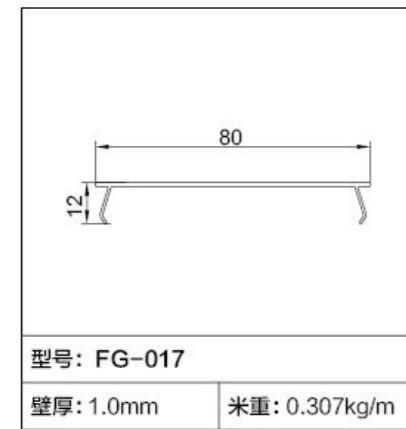
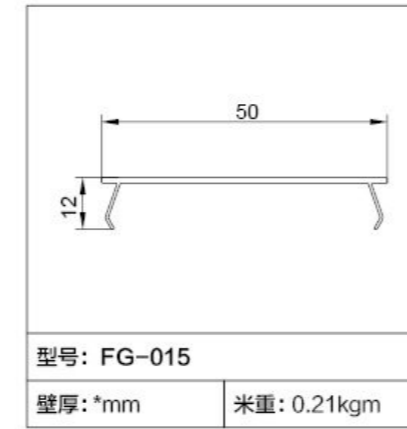
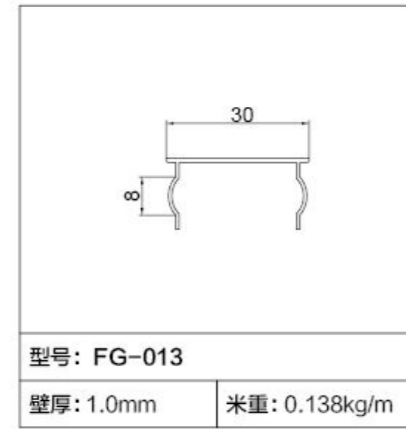
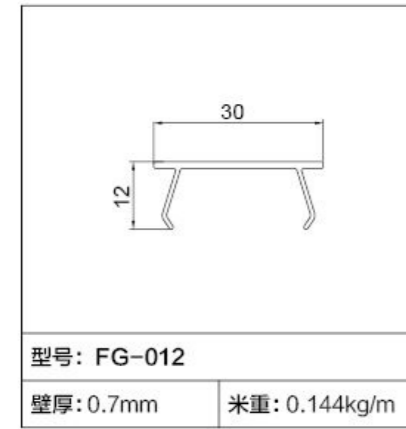

生活美学 安全耐用 健康环保 款式新颖 工艺领先

安全 · 环保 · 时尚 · 倡导者

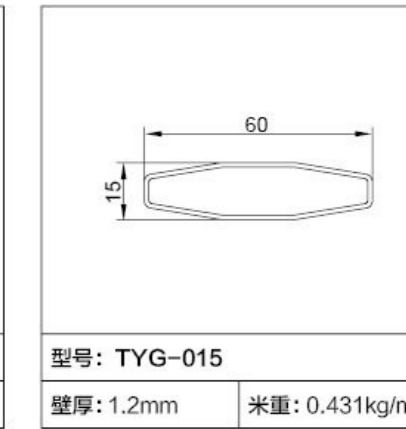
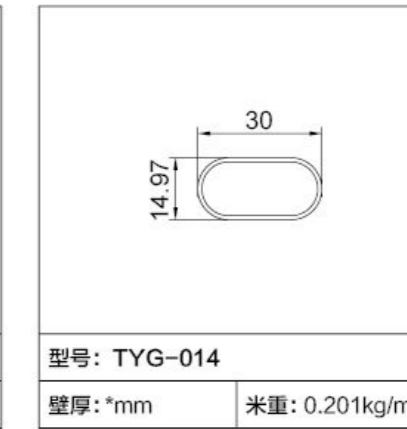
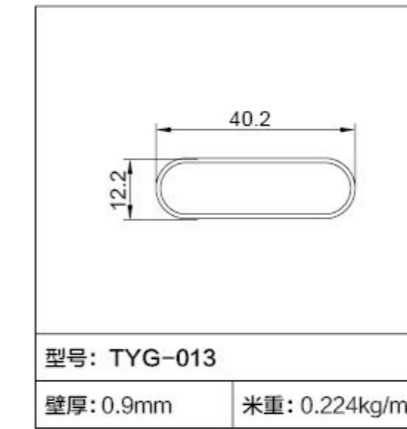
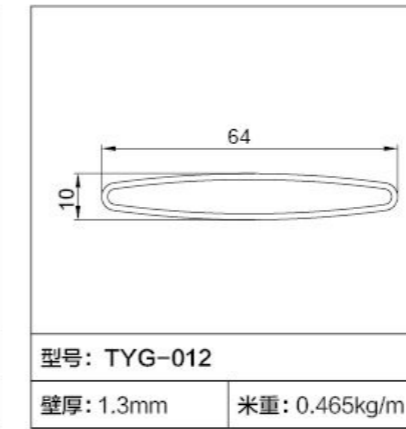
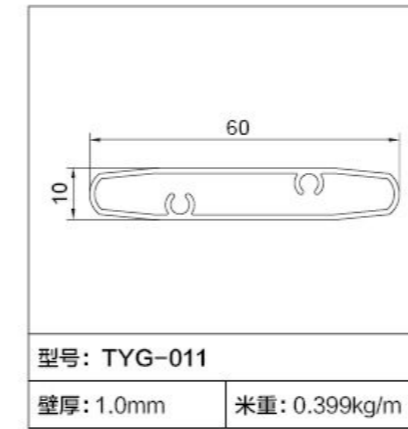
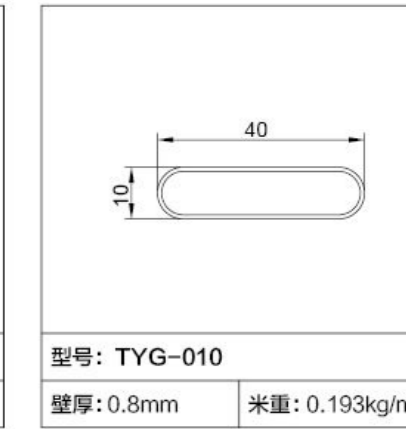
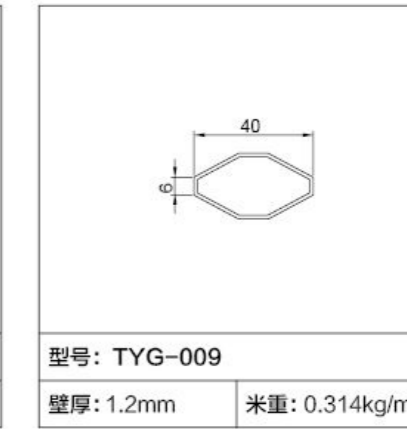
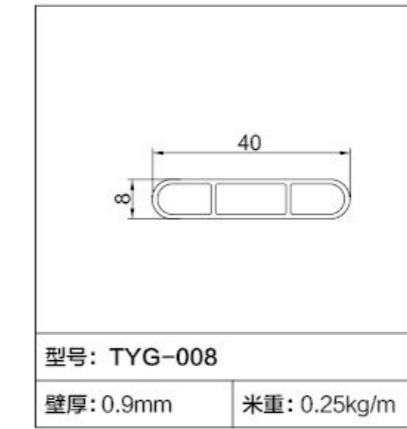
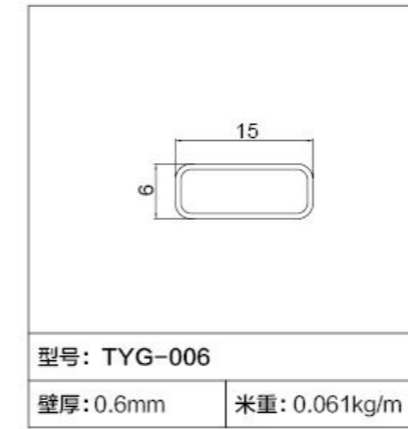

椭圆管 / 半圆管系列

Elliptical tube/semi-circular tube series

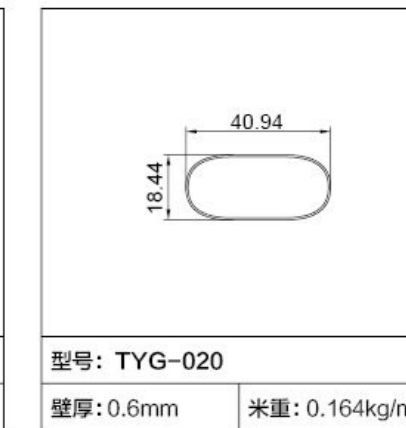
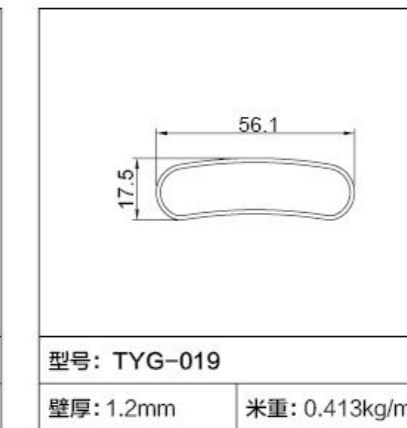
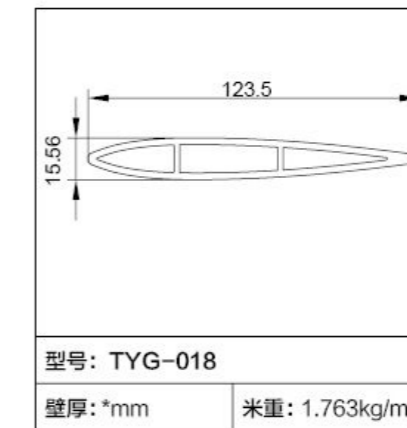
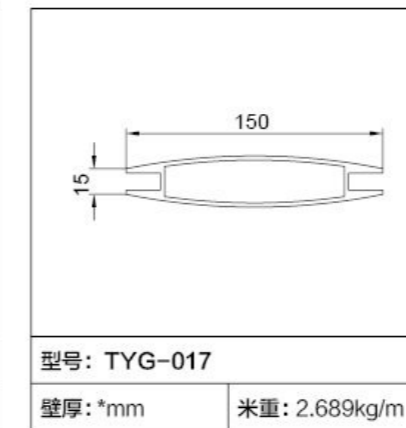
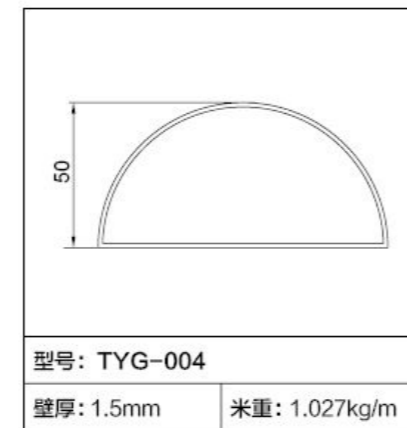
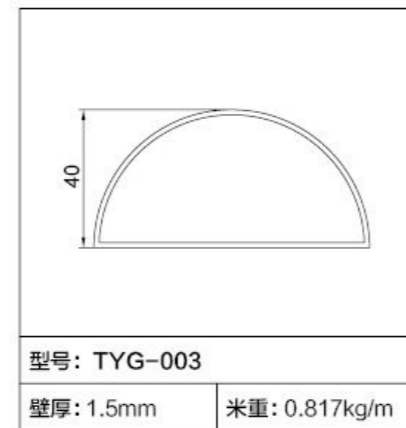
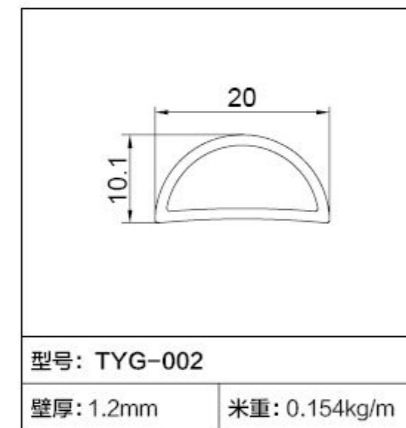
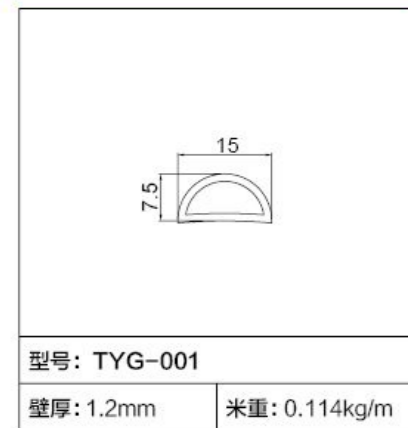

椭圆管 / 半圆管系列

Elliptical tube/semi-circular tube series

 优选材料
 精工制作
 钻石品质

U 型吊管系列

U-shaped hanging pipe series

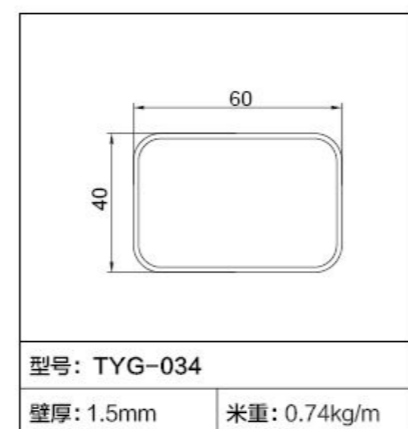
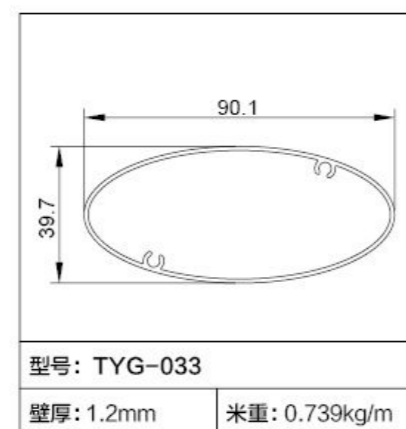
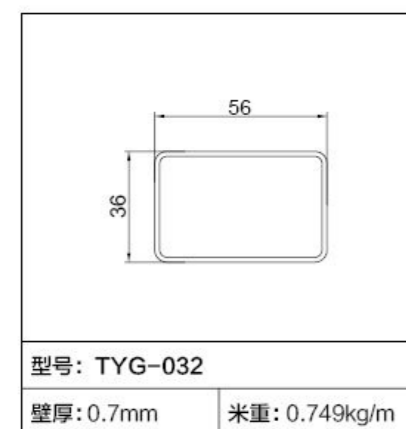
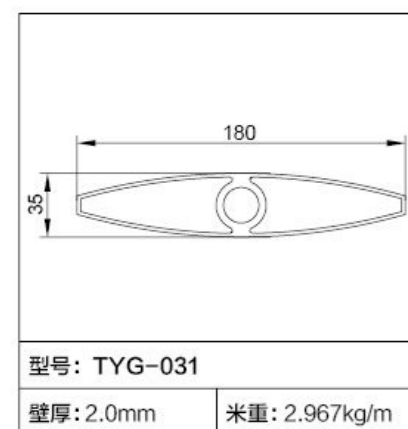
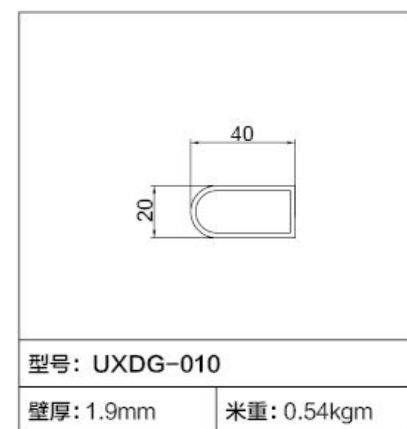
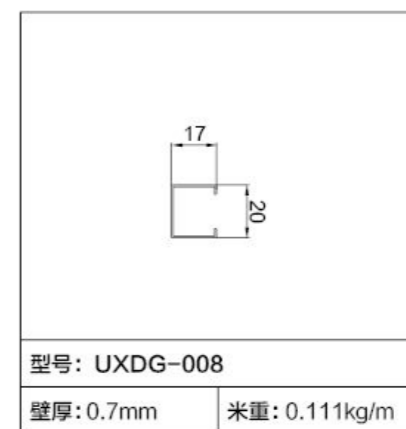
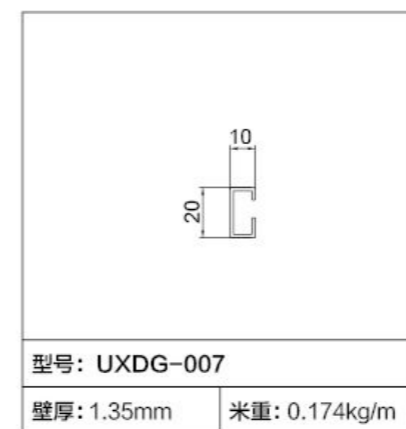
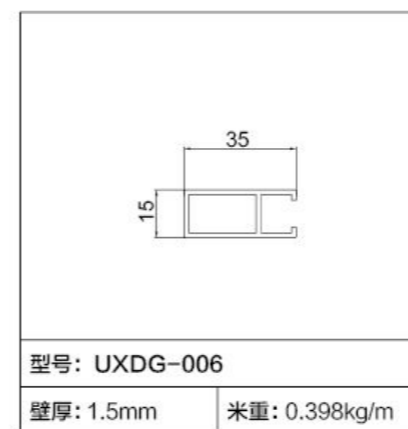
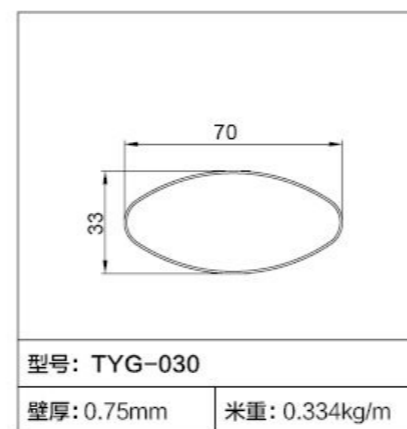
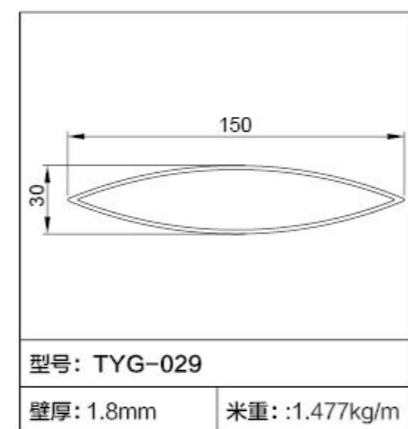
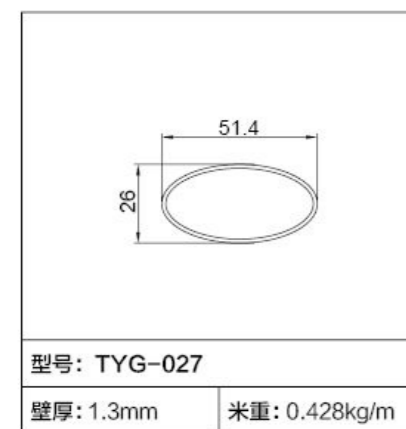
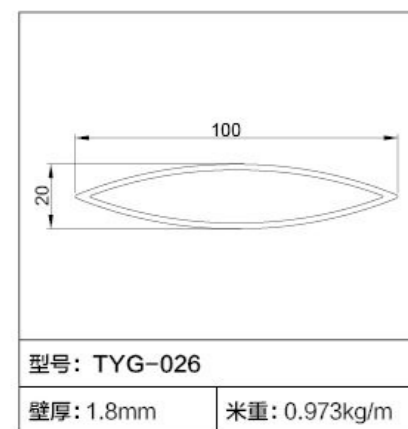
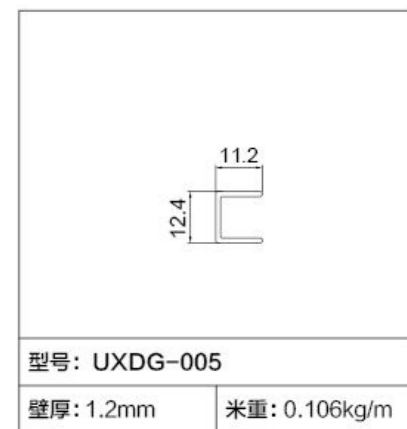
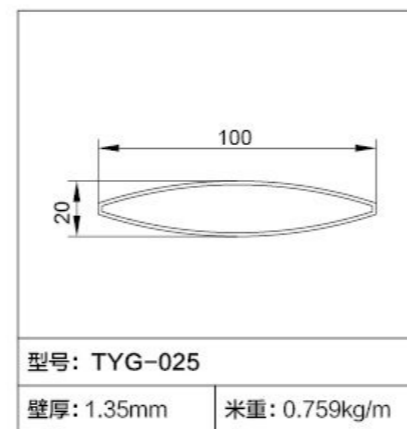
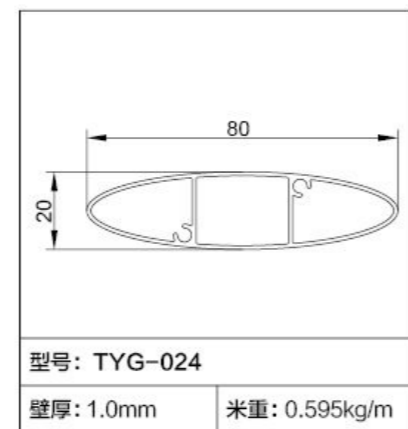
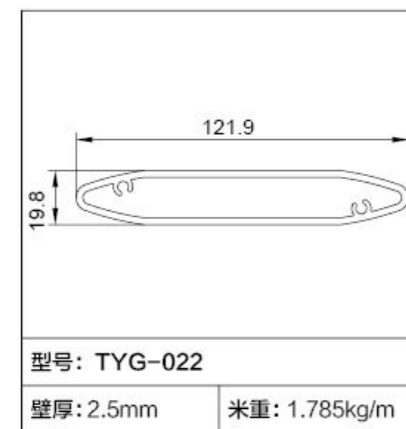
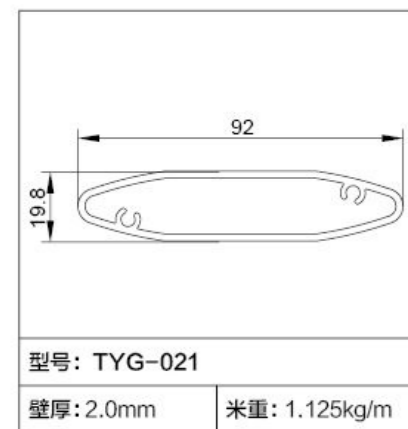

时 / 尚 / 典 / 雅
SIMPLE AND ELEGANT

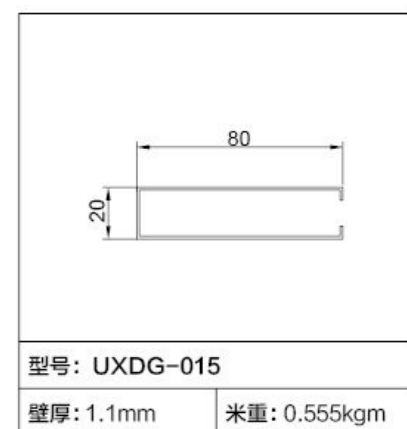
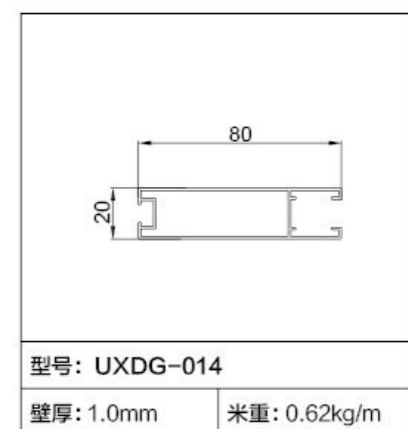
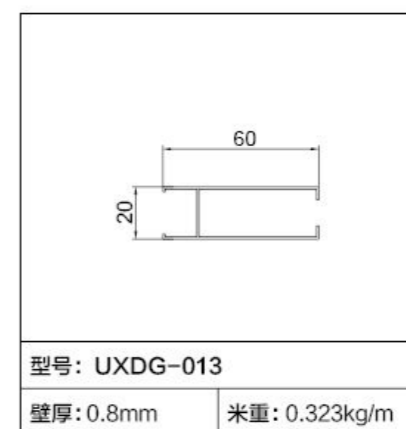
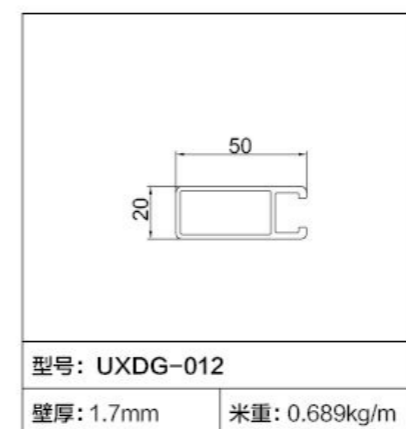
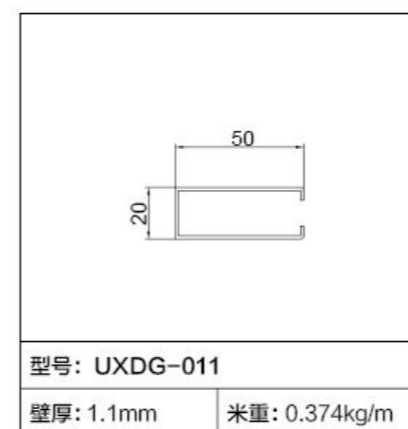

U 型吊管系列

U-shaped hanging pipe series



优选材料



精工制作



钻石品质

U 型吊管系列

U-shaped hanging pipe series

型号: UXDG-016
壁厚: 0.95mm 米重: 0.594kg/m

型号: UXDG-017
壁厚: 1.05mm 米重: 0.819kg/m

型号: UXDG-018
壁厚: 1.85mm 米重: 1.418kg/m

型号: UXDG-019
壁厚: 1.4mm 米重: 0.211kg/m

型号: UXDG-020
壁厚: 1.4mm 米重: 0.311kg/m

型号: UXDG-031
壁厚: 1.0mm 米重: 0.731kg/m

型号: UXDG-032
壁厚: 1.3mm 米重: 0.285kg/m

型号: UXDG-033
壁厚: 1.0mm 米重: 0.334kg/m

型号: UXDG-034
壁厚: 1.1mm 米重: 0.494kg/m

型号: UXDG-035
壁厚: 1.1mm 米重: 0.554kg/m

型号: UXDG-021
壁厚: 0.397kg/m 米重: 0.75mm

型号: UXDG-022
壁厚: 1.0mm 米重: 0.547kg/m

型号: UXDG-023
壁厚: 0.9mm 米重: 0.631kg/m

型号: UXDG-024
壁厚: 1.0mm 米重: 0.649kg/m

型号: UXDG-025
壁厚: 0.6mm 米重: 0.097kg/m

型号: UXDG-036
壁厚: 1.1mm 米重: 0.613kg/m

型号: UXDG-037
壁厚: 1.0mm 米重: 0.756kg/m

型号: UXDG-038
壁厚: 1.1mm 米重: 0.738kg/m

型号: UXDG-039
壁厚: 1.4mm 米重: 1.017kg/m

型号: UXDG-040
壁厚: 1.1mm 米重: 0.464kg/m

型号: UXDG-026
壁厚: 0.9mm 米重: 0.352kg/m

型号: UXDG-027
壁厚: 1.1mm 米重: 0.404kg/m

型号: UXDG-028
壁厚: 1.1mm 米重: 0.464kg/m

型号: UXDG-029
壁厚: 0.8mm 米重: 0.484kg/m

型号: UXDG-030
壁厚: 1.0mm 米重: 0.784kg/m

型号: UXDG-041
壁厚: 1.1mm 米重: 0.523kg/m

型号: UXDG-042
壁厚: 1.42mm 米重: 1.02kg/m

型号: UXDG-043
壁厚: 1.45mm 米重: 0.683kg/m

型号: UXDG-044
壁厚: 1.0mm 米重: 0.741kg/m

型号: UXDG-045
壁厚: 2.0mm 米重: 1.556kg/m

U 型吊管系列

U-shaped hanging pipe series



优选材料



精工制作



钻石品质

U 型吊管系列

U-shaped hanging pipe series



型号: UXDG-046	
壁厚: 1.1mm	米重: 0.643kg/m



型号: UXDG-047	
壁厚: 0.8mm	米重: 0.728kg/m



型号: UXDG-048	
壁厚: 0.85mm	米重: 0.721kg/m

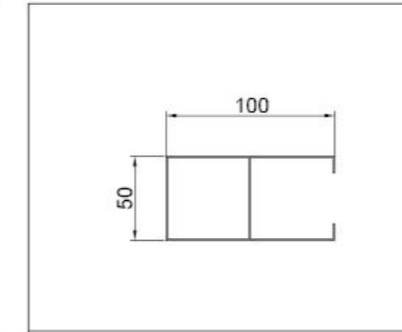

型号: UXDG-049	
壁厚: 0.85mm	米重: 0.728kg/m

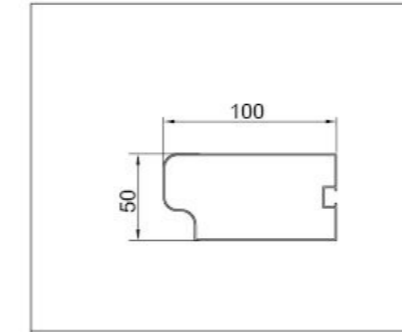

型号: UXDG-050	
壁厚: 0.9mm	米重: 0.746kg/m



型号: UXDG-061	
壁厚: 1.5mm	米重: 1.735kg/m



型号: UXDG-062	
壁厚: 2.0mm	米重: 2.175kg/m



型号: UXDG-063	
壁厚: 2.0mm	米重: 2.333kg/m

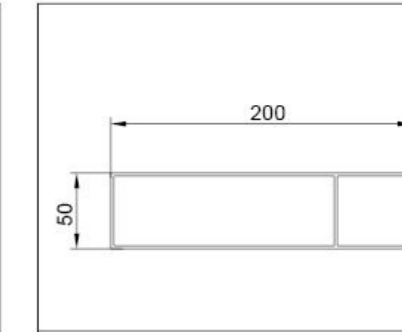

型号: UXDG-064	
壁厚: *mm	米重: 2.607kg/m

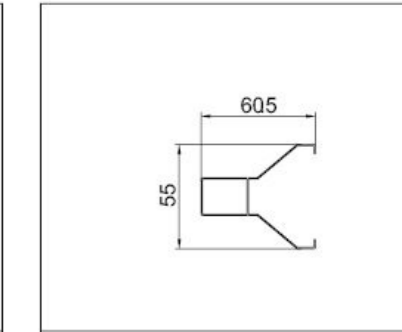

型号: UXDG-065	
壁厚: 1.5mm	米重: 1.507kg/m

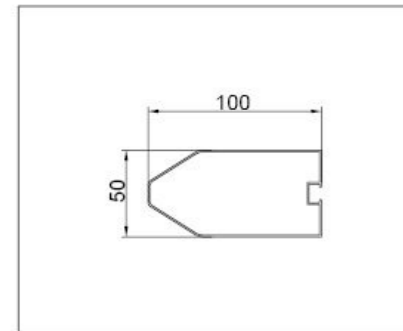

型号: UXDG-051	
壁厚: 1.0mm	米重: 0.781kg/m

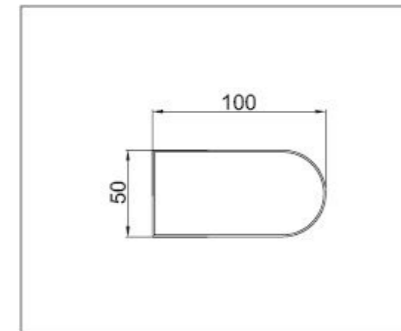

型号: UXDG-052	
壁厚: 1.1mm	米重: 0.822kg/m

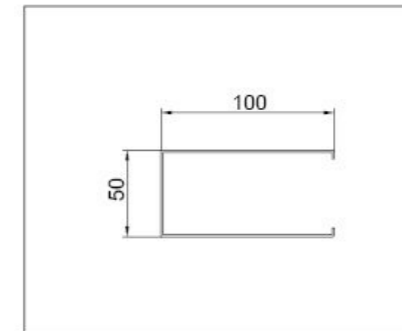

型号: UXDG-053	
壁厚: 1.1mm	米重: 0.763kg/m

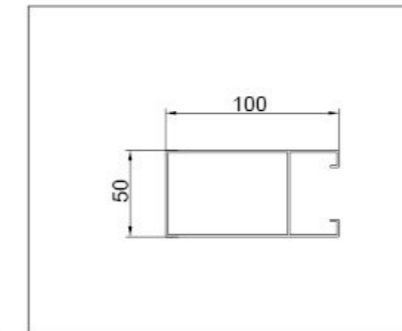

型号: UXDG-054	
壁厚: 1.2mm	米重: 1.045kg/m

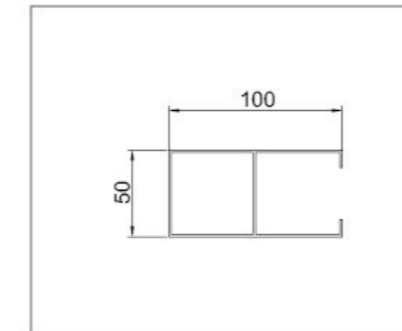

型号: UXDG-055	
壁厚: 1.35mm	米重: 1.145kg/m

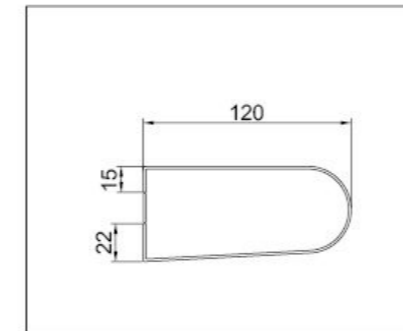

型号: UXDG-066	
壁厚: 1.4mm	米重: 1.213kg/m

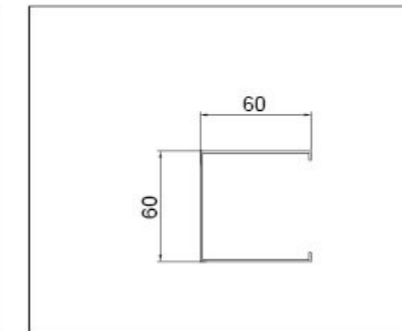

型号: UXDG-067	
壁厚: 1.1mm	米重: 0.553kg/m



型号: UXDG-068	
壁厚: 1.1mm	米重: 0.678kg/m

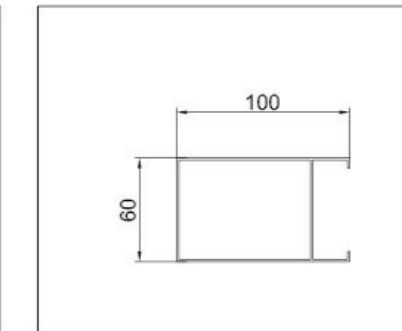

型号: UXDG-069	
壁厚: 1.35mm	米重: 1.185kg/m

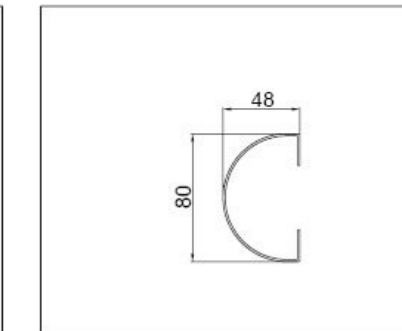

型号: UXDG-070	
壁厚: 1.35mm	米重: 0.664kg/m

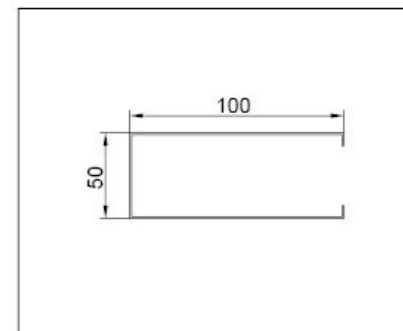

型号: UXDG-056	
壁厚: 1.4mm	米重: 0.768kg/m

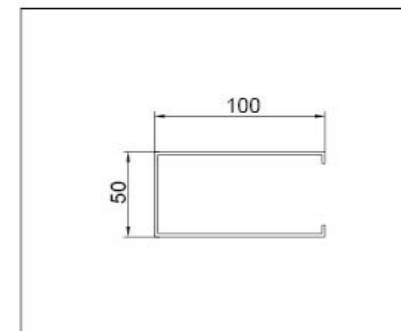

型号: UXDG-057	
壁厚: 1.85mm	米重: 1.29kg/m

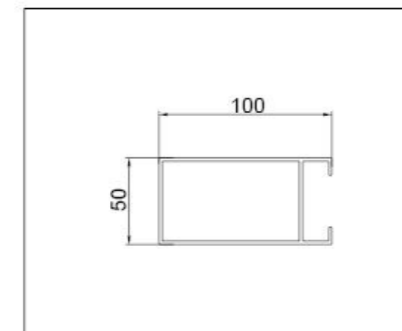

型号: UXDG-058	
壁厚: 1.9mm	米重: 1.6kg/m

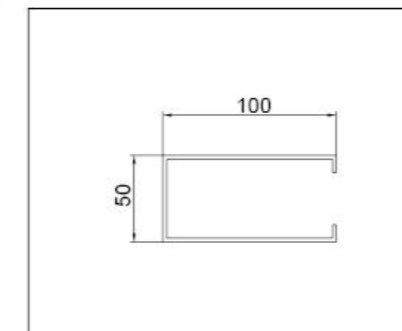

型号: UXDG-059	
壁厚: 2.2mm	米重: 1.563kg/m

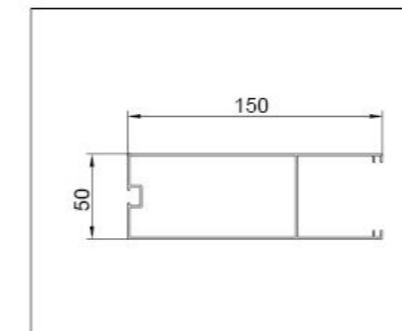

型号: UXDG-060	
壁厚: 1.1mm	米重: 1.285kg/m



型号: UXDG-071	
壁厚: 1.4mm	米重: 0.857kg/m



型号: UXDG-072	
壁厚: 1.4mm	米重: 1.041kg/m



型号: UXDG-073	
壁厚: 2.2mm	米重: 1.802kg/m

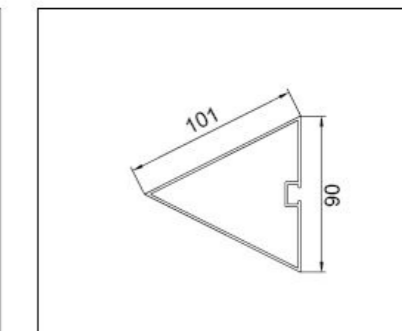

型号: UXDG-074	
壁厚: 1.5mm	米重: 1.244kg/m



型号: UXDG-075	
壁厚: 0.85mm	米重: 0.461kg/m

U型吊管系列

U-shaped hanging pipe series

 优选材料
 精工制作
 钻石品质

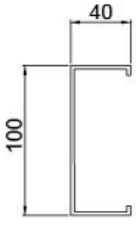

型号: UXDG-076
壁厚: 2.45mm 米重: 1.225kg/m



型号: UXDG-077
壁厚: 1.3mm 米重: 0.98kg/m



型号: UXDG-078
壁厚: 1.9mm 米重: 1.28kg/m



型号: UXDG-079
壁厚: 1.9mm 米重: 1.49kg/m



型号: UXDG-080
壁厚: 1.85mm 米重: 2.176kg/m



型号: UXDG-081
壁厚: 2.9mm 米重: 2.459kg/m



型号: UXDG-082
壁厚: 1.25mm 米重: 0.759kg/m

型号:
壁厚: 米重:

型号:
壁厚: 米重: 1.507kg/m

型号:
壁厚: 米重:



生活美学



安全耐用



健康环保



款式新颖



工艺领先

安全·环保·时尚·倡导者

SAFE. ENVIRONMENTALLY FRIENDLY. FASHIONABLE. ADVOCATE

方管系列

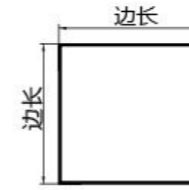

长	宽	壁厚	备注
8	8	1	
10	10	0.7	
		1.0	
		1.2	
		1.4	
		1.5	
		1.5	
14	9.9	0.6	
15	10	0.7	
		1.0	
		1.2	
		1.4	
	15	0.8	
		1.0	
		1.2	
		1.4	
		2.0	
		2.0	
17.7	10.8	0.6	
19.3	12.2	0.75	
19.5	17	0.8	
		1.35	
19.8	6.6	0.7	
20	10	0.8	
		1.0	
		1.2	
		1.4	
		2.0	
		2.0	
	16	1.0	

方管系列

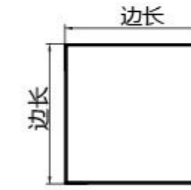

长	宽	壁厚	备注	
20	20	0.9		
		1.2		
		0.7		
		1.4		
		2		
25	10	0.8		
		1.0		
		1.4		
	25	0.9	四个面有装饰线	
		0.75	四个面有装饰线	
	25	25	0.6	
			0.8	
			1.0	
			1.2	
			1.5	
30	10	0.6		
		1.0		
		1.2		
	15	1.0		
		1.2		
	20	20	0.8	
			1.0	
			1.2	
			1.4	
			2.0	

方管系列

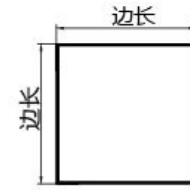

长	宽	壁厚	备注	
30	20	1.4		
		1.7		
		2.0		
	25	1.0		
		1.2		
		2.0		
	30	30	0.5	
			0.6	
			0.65	
			0.7	
0.7			四个面有装饰线	
0.8				
0.9				
1.2				
1.4				
1.8				
2.9				
35	25	0.8		
	35	1.0		
		1.2		
35	35	2.0		
		2.0		
36	36	0.6		
38	38	20	0.6	
		25	1.0	
		25	2.0	
		35	2.5	
		38	0.6	

方管系列

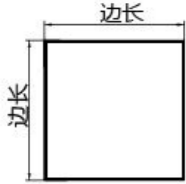

长	宽	壁厚	备注
40	10	0.8	
		1.0	
		1.2	
		1.4	
	15	1.2	
	20	0.7	
		0.9	
		1.2	
		1.5	
		1.7	
		2.0	
	25	0.65	
		0.9	
	30	0.8	
		1.0	
		1.2	
		1.4	
		1.5	
		1.8	
	35	2.5	
		0.6	
	40	0.7	
		0.9	
		1.0	
		1.2	

方管系列

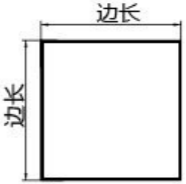

长	宽	壁厚	备注
40	40	1.35	
		1.5	
		2.0	
		2.2	足厚
45	2.2	0.55	
		1.2	
50	10	0.8	
		1.0	
		1.2	
		1.4	
		1.0	
		1.2	
	15	1.0	
		1.35	
		1.8	
	18.5	1.1	
	20	0.8	
		1.0	
	20	1.1	
		1.5	
	25	0.5	
		0.6	
		0.65	
		0.7	
0.8			
0.9			
1.0			
1.2			
1.5			
30	0.65		
	0.8		
	1.0		
30	1.0		
	1.2		
30	1.35		
	2.0		
30	0.6		
	2.4		

方管系列

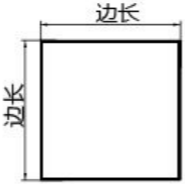

长	宽	壁厚	备注	
50	30	0.7		
		0.9		
		0.8		
		1.0		
		1.2		
		1.4		
		1.9		
		2.95		
		40	0.8	
			1.2	
	1.4			
	2.0			
	4.8			
	0.55			
	50	0.6		
		0.65		
		0.7		
		0.8		
		0.9		
		1.0		
		1.2		
		1.4		
		1.5		
		1.65		
		2.0		
		2.4		

方管系列

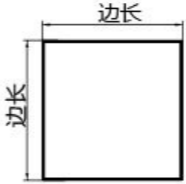

长	宽	壁厚	备注
50	50	3.0	
60	10	0.8	
		1.0	
		1.2	
		1.4	
		0.5	
		0.75	
	20	0.8	
		1.0	
		1.2	
		1.4	
		2.0	
		0.8	
	25	0.8	
		1.0	
	30	0.7	
		0.8	
		1.0	
		1.15	
		1.4	
		1.55	
		1.9	
		0.7	
	40	0.8	
		0.9	
		1.0	
		1.15	
		1.5	
		1.9	
40	1.0		
	1.15		
40	1.4		
	1.4		

方管系列

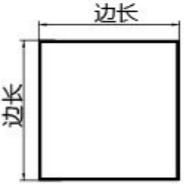

长	宽	壁厚	备注
60	30	1.0	
		1.15	
		1.4	
		1.55	
		1.9	
		0.7	
	40	0.8	
		0.9	
		1.0	
		1.15	
		1.4	
		2.0	
	45	1.18	
	50	0.8	
		1.0	
	50	1.2	
		1.8	
	60	2	
		0.7	
		0.75	
		0.9	
		1.0	
		1.2	
		1.5	
		1.9	
	60	3.5	
		1.4	

方管系列

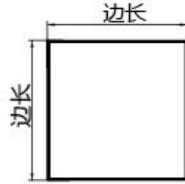

长	宽	壁厚	备注
62	30	1.8	
65	25	1.8	
	50	0.7	
68	44	1.15	
	10	1.0	
70	10	1.2	
		1.4	
		0.8	
	20	1.0	
		1.2	
		1.4	
	30	0.8	
		1.0	
		1.2	
		1.4	
		1.9	
		0.8	
40	1.0		
	1.2		
	1.4		
	1.9		
	2.8		
	0.8		
50	1.0		
	1.2		
	1.4		

方管系列

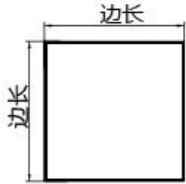

长	宽	壁厚	备注
70	50	1.9	
		1.0	
	60	1.2	
		1.4	
		1.2	
	70	1.4	
		2.0	
2.0			
75	15	1.0	
	20	1.05	
		1.8	
	25	0.7	
	50	0.75	
		1.2	
		1.8	
1.8			
76	25	0.8	
		1.0	
		1.2	
		1.4	
		2	
	44	1.0	
		1.2	
		1.4	
80	10	1.0	
		1.2	
	15	1.4	
		0.8	
		0.8	

方管系列

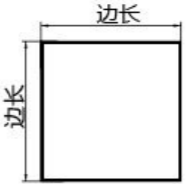

长	宽	壁厚	备注
80	20	0.8	
		0.9	
		1.0	
		1.0	
		1.2	
		1.65	
		2.0	
		3.85	
	25	0.8	
		1.0	
		1.2	
		1.5	
		2.0	
		2.0	
	30	0.9	
		1.0	
		1.2	
1.4			
2.0			
0.6			
0.65			
0.7			
40	0.8		
	1.0		
	1.2		
	1.2		
	1.3		
	1.4		
	1.4		
	1.7		
	2.0		
	2.0		

方管系列

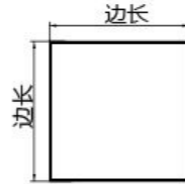

长	宽	壁厚	备注
80	45	0.75	
	50	0.8	
		1.0	
		1.2	
		1.4	
		1.8	
		2.0	
		2.0	
	60	0.75	
		0.8	
		1.0	
		1.2	
		1.4	
		1.8	
	80	1.0	
		1.2	
		1.4	
1.9			
2.85			
2.85			
90	10	1.0	
		1.2	
		1.4	
	20	1.0	
		1.2	
		1.4	
		2.0	
	25	1.0	
		1.2	
		1.2	

方管系列

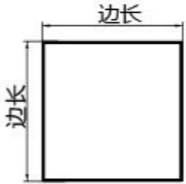

长	宽	壁厚	备注
90	25	1.4	
		1.4	
	30	1.0	
		1.2	
		1.4	
		2.0	
		3.85	
		3.85	
	40	1.0	
		1.2	
		1.4	
		2.0	
		2.0	
		2.0	
	50	1.0	
		1.2	
		1.4	
2.0			
2.0			
2.0			
60	1.0		
	1.2		
	1.45		
	2.0		
	2.0		
	2.0		
70	1.0		
	1.2		
	1.4		
	1.4		
95	40	0.75	
100	10	1.0	
		1.2	
		1.4	
	15	1.0	
		1.2	

方管系列

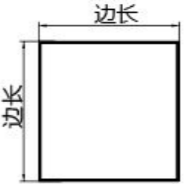

长	宽	壁厚	备注
100	15	1.4	
		1.4	
	20	0.8	
		1.0	
		1.1	
		1.5	
		1.9	
		1.9	
	25	0.8	
		1.0	
		1.2	
		1.4	
		2.0	
		2.0	
	30	0.7	
		0.8	
		1.0	
		1.2	
		1.4	
		1.8	
2.0			
2.0			
40	0.7		
	0.8		
	1.0		
	1.2		
	1.3		
	1.95		
44	0.8		
	1.0		

方管系列

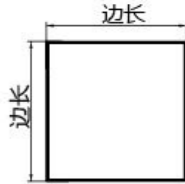

长	宽	壁厚	备注
100	44	1.2	
		1.35	
		1.4	
		2.0	
		2.0	
	45	1.0	
		1.5	
	46	1.5	
		1.5	
	50	0.7	
		0.8	
		0.85	
		0.9	
		0.95	
		1.0	
		1.1	
		1.35	
		1.45	
		1.5	带螺丝孔
		1.8	
2.0			
2.5			
3.0			
60	0.8		
	1.0		
	1.2		
	1.4		
	1.8		
70	1.0		
	1.2		



烤漆色铝方管

规格齐全，接受各类异型材定制

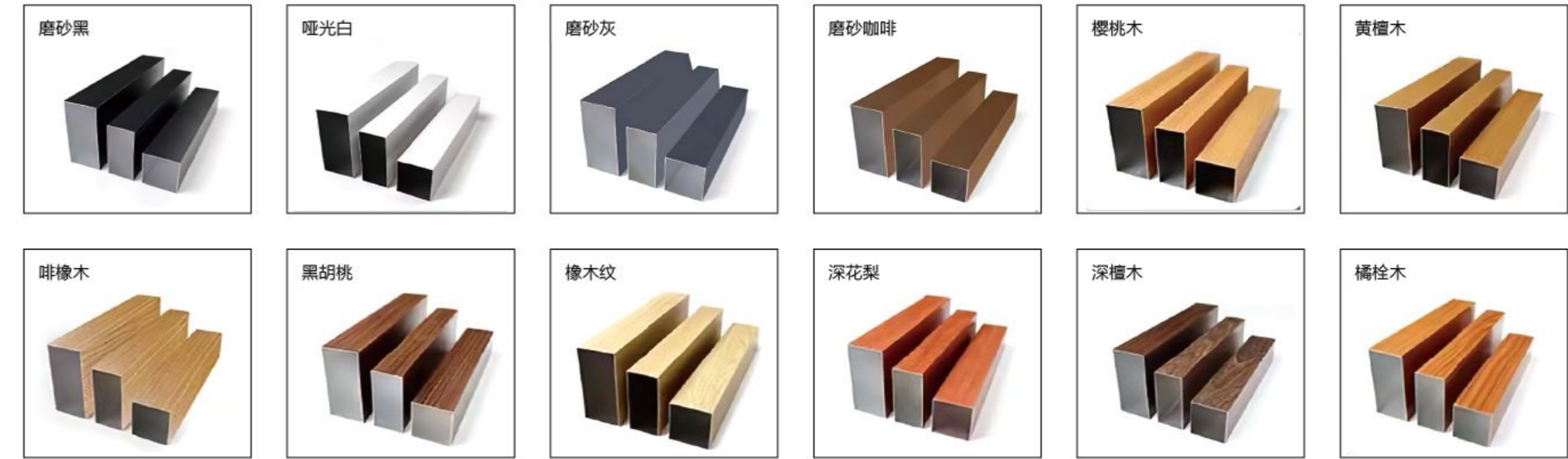

木纹色 U 型方通

规格齐全，接受各类异型材定制

